

# "TOTAL PACKAGE"<sup>®</sup>

COMPONENT COMPATIBLE FALL PROTECTION SYSTEM

by **SUPER ANCHOR SAFETY**

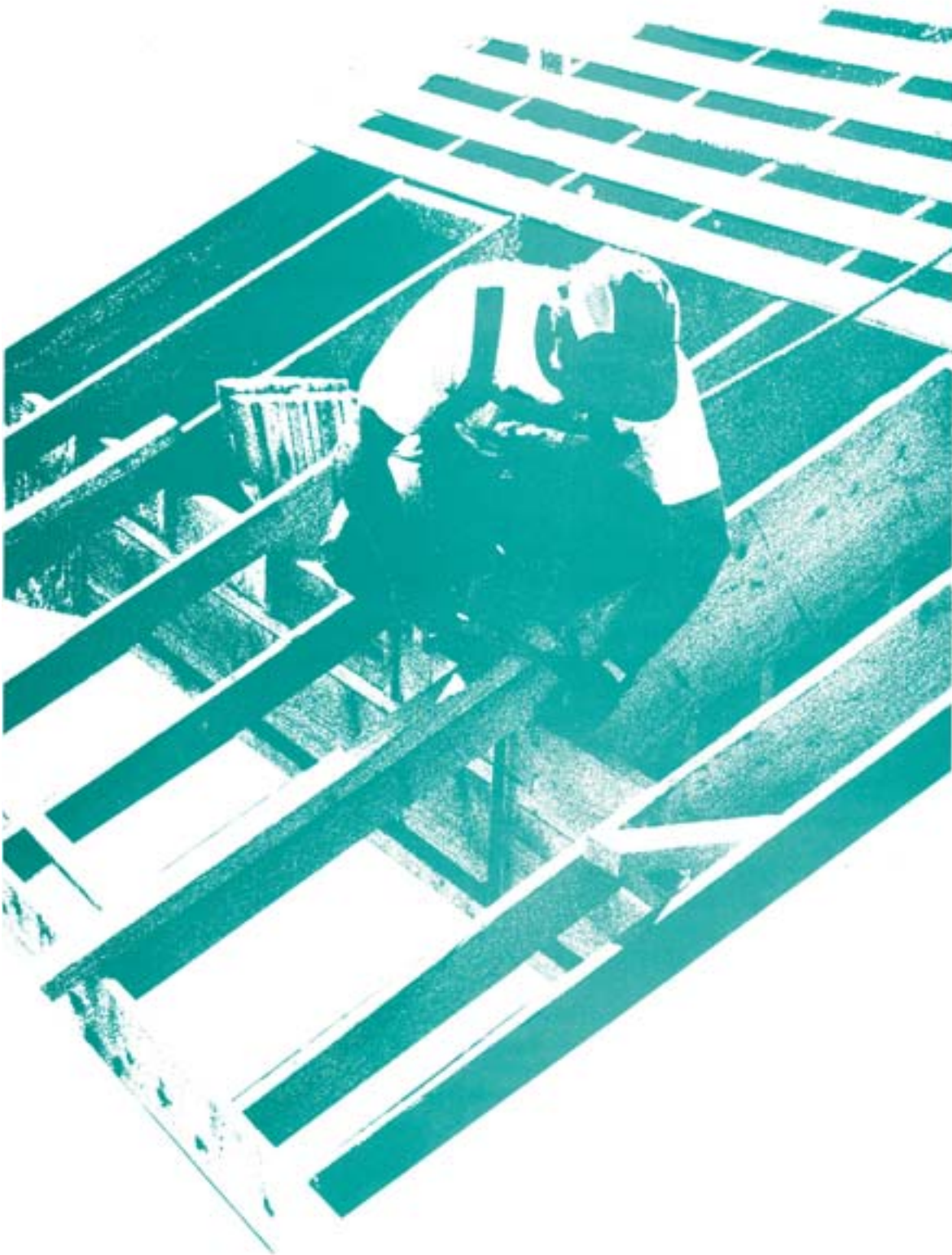

**F  
A  
L  
L  
  
P  
R  
O  
T  
E  
C  
T  
I  
O  
N  
  
M  
A  
N  
U  
A  
L**



# WARNING TO USER



## ATTENTION:

- ❑ EMPLOYERS
- ❑ USERS OF SAFETY EQUIPMENT
- ❑ SAFETY PERSONNEL
- ❑ PURCHASERS OF SAFETY EQUIPMENT

OSHA REGULATIONS REQUIRE THAT ANY WORKER EXPOSED TO A FALL HAZARD IS REQUIRED TO HAVE FALL PROTECTION.\*

REFER TO CFR 29-1926; 500-503 SUB-PART (M) FALL PROTECTION

## FALL PROTECTION BASICS AND JOB SITE SAFETY

- ❑ The improper use of safety equipment can create hazards that may result in serious injury or death. Follow all instructions closely and observe warnings.
- ❑ Systems using components supplied by more than one manufacturer may not be interchangeable and could also create unforeseen hazards.
- ❑ Employers & users of safety equipment are required by law to provide a comprehensive training program that complies with CFR 29-1926;503.
- ❑ Each employee or user must first read, understand, and receive training from the manufacturer's "Specification/ Instruction" Manual for each type of component, before ever using the equipment for fall protection.
- ❑ Training & instruction must be carried out by a "Qualified or Competent" person and the training must be documented in writing.
- ❑ The employer should hold regular safety meetings and provide ongoing instruction for all employees using safety equipment.
- ❑ OSHA standards should be regarded as a minimum requirement.
- ❑ This manual should be carefully studied by all persons that will be using this equipment or giving training and instruction.
- ❑ It is advised that employers have a written Fall Protection Plan that can be modified for "Job Specific" circumstances which addresses the hazards of each project.

\* Standards may vary depending on individual state Fall Protection regulations.



# TOTAL PACKAGE®

## Instruction and Specification Manual:

This manual is compiled from “**Instruction / Specification**” safety manuals for equipment contained in the **FALL ARRESTOR®**, “**TOTAL PACKAGE**” and “**VALUE PAK®**” Information regarding the use of Fall Arrest, Fall Restraint, Lifelines, Body Harness and attachment hardware is contained along with a sample outline for user safety meetings specific to this equipment. All the individual instructional materials contained in this manual are available upon request.

### NOTICE TO USER OR PURCHASER OF SAFETY EQUIPMENT

You must first read, understand, and receive training from the following “**Instruction/Specification**” manuals before using the equipment.

### Contents of this Manual:

#### REQUIRED INSTRUCTIONS FOR USE

- Warning to User .....page 2
- How to Install Fall Protection Equipment .....pages 4 & 5
- Carabiner Instructions .....pages 6 & 7
- Swing Fall Hazard .....page 8
- Body Harness Attachment Instructions .....page 9
- Instructions for Attaching Lifelines,  
Lanyards and Shock Absorbers .....page 10
- Length of Fall: “Sample Plan” .....page 11
- Compatibility Chart  
Nylon Ring/D-Ring Harness .....page 12
- User’s Daily Checklist .....page 13

#### ADDITIONAL INFORMATION

- Anchor Part Information .....pages 14 & 15
- Fall Arrestor®  
Instruction/Specification Manual .....pages 16 - 21
- Compatibility Chart  
D-Ring Harness .....page 22
- Compatibility Chart  
Nylon-Ring Harness .....page 23
- Compatibility Chart  
Anchorage Connections .....page 24
- Non-Compatibility Chart  
Locking Snaphook/Locking Carabiner .....page 25
- Super Anchor®  
Instruction/Specification Manual .....pages 26 - 31
- Super Anchor® ARS 5K Re-Useable Anchor  
Instruction/Specification Manual .....pages 32 - 35
- Super Anchor® ARS 3K Re-Useable Anchor  
Instruction/Specification Manual .....pages 36 & 37
- Super Anchor® Universal Anchor  
Instruction/Specification Manual .....pages 38 - 41
- Super Anchor® Moveable ARS Anchor  
Instruction/Specification Manual .....pages 42 & 43
- Super Anchor® Retro-Fit Anchor  
Instruction/Specification Manual .....pages 44 & 45
- User Training Form .....pages 46 & 47

## **How to Install the TOTAL PACKAGE® Personal Fall Protection System.**

### **Instructions for attaching FALL ARRESTOR® Lifeline/Rope Grab System to the Full Body Harness.**

The **“TOTAL PACKAGE”** includes the following components:

**FALL ARRESTOR®** Lifeline / Rope Grab System - 30 or 50 Ft. Length

**FALL ARRESTOR®** Full Body Harness, with Shock Absorbing Lanyard attached.

2 Auto-Locking Carabiners, Part #5006, anodized red

1 ARS 3-K Non-Reusable Anchor w/Stainless Spiral nails

1 Carry Bag with Serial Number and Identification Tag Area

1 Instruction Specification Manual for **“Total Package”** System

Free Instructional Video upon request. (Fax order form included in package.)

**“Value Pak” System** includes a 30' or 50' Lifeline with Rope Grab, Full Body Harness with Shock Absorbing Lanyard, two Double Locking Snaphooks, a 3.5 Gallon Pail, one ARS 5K Temporary/Re-useable Fall Arrest Anchor and an Instruction Manual.



## **WARNING TO USER**



The **“Total Package”** is a personal fall protection system for use in fall arrest and fall restraint applications. All of the above **“specified”** components have been designed for compatibility. Do not make any replacements, substitutions, or changes in the **“specified”** components without first making sure those components are compatible. It is the responsibility of the purchaser and/or user to ensure component compatibility. Replacement equipment for the above **“specified”** components may be purchased from any of our authorized distributors.

### **IMPORTANT TO READ THE FOLLOWING INSTRUCTIONS FOR USE.**

The body harness supplied as part of this **“Total Package”** system has been fitted with a shock absorbing lanyard. In the event of a fall, up to 42" of fabric will be ripped out of the lanyard, thus adding an extra 3-1/2 Ft. to the distance you fall. It is important that you read the following instructions so you can avoid serious injury or death in the event of a fall. (See Page 11 regarding **“Length of Fall”** and Page 8 of this manual on **“Swing Fall Hazard”**.)

- 1) The Full Body Harness has a shock absorbing lanyard attached with a nylon ring. **Do not remove or replace the shock absorbing lanyard in this system. Do not attach any snap hook to the nylon ring of the body harness. (See NON-COMPATIBILITY SECTION ON PAGE 12.)**

### **ATTACHING SHOCK ABSORBER TO LIFELINE:**

- 2) An auto locking carabiner has been attached to the web loop at the end of the shock absorbing lanyard. Attach this carabiner to the rope grab by inserting the carabiner through the oval shaped plastic eye thimble end. **MAKE SURE THE CARABINER IS IN THE LOCKED POSITION BEFORE YOU USE THE SYSTEM FOR FALL PROTECTION!!!**

**WARNING:** Do not use any other type of attachment hardware, any other method of attachment, and do not substitute the factory supplied carabiner with any other type of carabiner. Use only the factory approved carabiner.

### **BODY HARNESS ADJUSTMENT**

- 3) The full body harness must be properly adjusted before use. Refer to pages 9, 10, 11 and 12 and 16, 17, 18, 19, 20 and 21 of the **FALL ARRESTOR® Instruction/Specification Manual** included as part of this manual for instructions.

**MAKE SURE THE HARNESS IS ADJUSTED CORRECTLY BEFORE USING.**

**DO NOT REMOVE ANY WARNING LABELS OR SERIAL NUMBER TAGS.**

## **POSITIONING THE ROPE GRAB FOR EASY ADJUSTMENT:**

4) The Rope Grab should hang somewhere below your waist and not lower than your knees. The ideal position will be a matter of your personal preference. However, the Rope Grab should not be allowed to drag on the work surface and should be easy to reach while working. **(See Fig. 9 on page 9)**

A) **To Position:** The Rope Grab is adjusted by raising or lowering the shoulder strap cross brace called the chafe pad located in center of your back on the harness. **(See Fig. 7 on page 9.)** Feed the Right and Left hand shoulder straps through the plastic pad in either direction. Locate the pad just below your shoulders in the center of your back.

B) **Adjustment:** If the proper adjustment can not be made, (allowing the Rope Grab to hang just below your waist), Do Not Use the System and contact your distributor.

## **PLANNING THE FALL HAZARD:**

5) In the event that you fall, the shock absorbing lanyard will rip out to a length of approximately 42" maximum. You must be sure to include this 3-1/2 Ft. when considering fall hazards on the job, such as stacked building materials, or scaffolding that may be directly under or near your work area. **(See page 11)**

## **SWING FALL HAZARD:**

6) If you are working off-center from the anchorage point, (that is, to the left or right of the anchor, at an angle), and you fall over the gable edge or eave line, you will swing toward the center point directly below the lifeline's anchorage point. Be sure to take this potential hazard into consideration when you are working. You could slam into obstacles below during the swing part of the fall. **(See page 11)**

## **IF YOU FALL:**

7) In the event that you fall, the shock absorber as well as all the fall protection equipment must be removed from service. This is in accordance with OSHA 1926.104a. You must replace every single component that was in use when the fall occurred. This includes the anchorage point as well as the locking carabiners.

8) With all the above attachments completed and inspected, you are now ready to proceed with your work.

9) Always store your safety equipment in dry condition. Never put away wet or damp.

Access to the anchorage point for the purpose of attaching a lifeline may require worker fall protection. OSHA and individual state safety standards regarding compliance in this situation, may vary depending on local enforcement policies.

## **CONTINUED INSTRUCTIONS:**

10) Before you use this system, you must read the following materials as part of the "Instruction/Specification" manual of the **"TOTAL PACKAGE"**.

**FALL ARRESTOR® INFORMATION** - Visual instructions for installation of the body harness and lifeline/rope grab system. Includes Length of Fall "Sample Plan."

Page 6-7 Carabiner Instructions

Page 8 Swing Fall Hazard

Page 9 Body Harness Attachment Instructions

Page 10 Instructions for Attaching Lifelines, Lanyards and Shock Absorbers

Page 11 Length of Fall "Sample Plan"

Page 12 Compatibility Chart - Nylon Ring/D-Ring Harness

11) We recommend viewing our Fall Protection Video which is available, free of charge.

# CARABINER INSTRUCTIONS FOR USE

Auto Locking Type Part No. 5006

1/2" Aluminum 30 KN. = 6,744 lbs.

## SPECIFIED USE:

**Attachment of Lifeline to an approved anchor device**  
**Attachment of Body Harness connecting lanyard to Rope Grab**  
**Attachment of Connecting Lanyard or Shock Absorber to Body Harness**

## **WARNING**

It is important to read and understand the following instructions for Carabiner use. The specified attachments requiring a locking carabiner are a vital function of your "Personal Protection System" and equipment. Your life may depend on proper function of the carabiner. Observe the following instructions.

**DO NOT USE AN AUTO-LOCK CARABINER WITHOUT MAKING SURE THE GATE IS FULLY CLOSED AND IN THE LOCKED POSITION**

**INSPECT YOUR CARABINER BEFORE EACH USE**

**DO NOT USE A DEFECTIVE CARABINER**

### 1) CARABINER IN OPEN AND FULLY LOCKED POSITIONS:

Never assume the carabiner gate is in the fully locked position. The gate is equipped with a spring that automatically closes the gate. The "Locking Sleeve" must be opened by twisting it and pushing inwards. (See Fig. 1 below.) Check for positive "Closed Position" by trying to open the gate by pushing against it. If the Gate does not open, it is in the closed position. (See Fig.2 below.)

### 2) INSPECTION OF THE CARABINER:

The following list of defects renders the carabiner "Defective."  
If any of the following defects exist, **DO NOT USE THE CARABINER.**  
Replace it with a new one immediately.

- A) Gate will not close on its own. Gate close spring is defective.
- B) Locking Sleeve will not stay closed, or is hard to open or close.
- C) Carabiner Gate, Body, or Locking Sleeve has surface scrapes, gouges, or other defects that affect the integrity of the carabiner's strength.
- D) Carabiner gate will not close or lock into carabiner housing.  
**See Fig. 1.**
- E) Carabiner is twisted or bent, has been damaged, or has been subjected to a fall impact.
- F) Gate keeper pin, or keeper ring is missing, or coming loose.

### 3) WHEN A FALL OCCURS:

Federal OSHA Law requires that any Personal Fall Protection equipment, such as a carabiner, must be replaced if subjected to a fall impact. **DO NOT USE THE CARABINER.** Render it unusable by cutting it in half or removing the gate and then dispose of it. Replace it with a new carabiner, immediately.

### 4) MAINTENANCE:

Inspect the carabiner and its functions before each use. The Gate should close by itself, provided the gate spring is working properly. The Locking Sleeve should open and close easily without the use of any tools or excessive force. The Locking Sleeve can be cleaned by the use of compressed air. Remove any surface contamination such as grease, oil, caulking, or other materials by the use of cleaning solvents and a clean rag. It is important to make sure that no residual cleaning material is left on the carabiner.

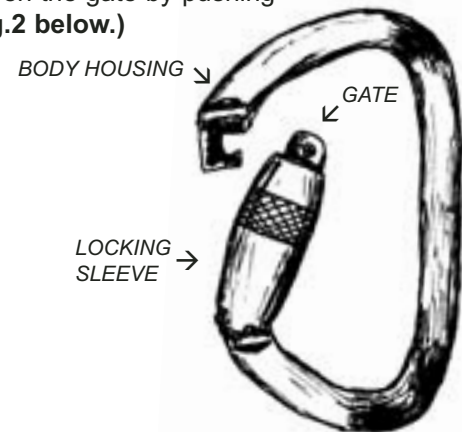

**FIG 1**  
GATE IN OPEN POSITION



**FIG 2**  
GATE AND LOCKING SLEEVE  
IN CLOSED POSITION

5) **NON-SPECIFIED USES: →NEVER USE A CARABINER FOR ANY OF THE FOLLOWING**

- A) Use only for personal fall protection as specified on page 1. **DO NOT USE** for towing, lifting, or hoisting materials.
- B) Do not attach more than one person, more than one lifeline, or more than one connecting device to a carabiner at any time. In the event of a fall, the carabiner specified in this instruction manual, is rated to sustain forces generated by one person only. **Exceeding that specification may result in failure and cause death or serious injury.**

- C) Do not connect two carabiners together. **See Fig. 5.1.**

Do not connect a carabiner to a snap hook. **See Fig. 5.2.**

Do not connect a carabiner to any anchorage device that does not specifically give instructions for use of carabiners as an attachment device.

- D) Do not allow the carabiner gate to come in contact with the anchor attachment. **See Fig. 6.2.** below.

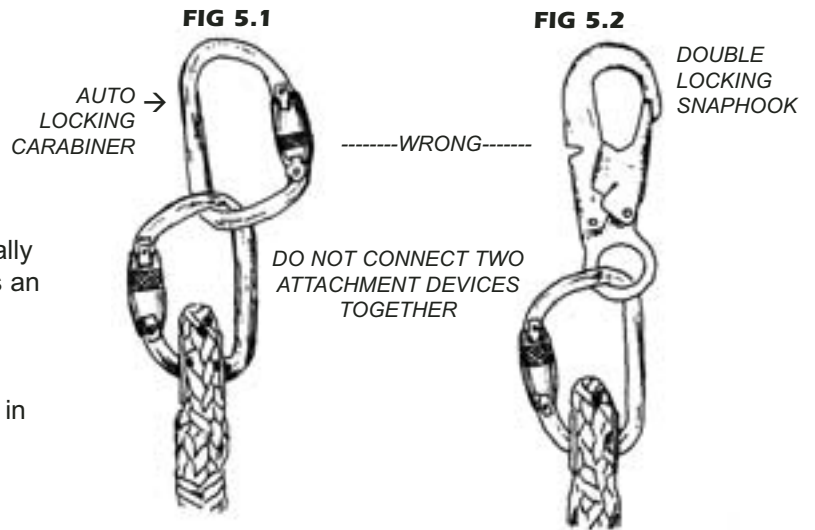

An auto locking carabiner is a superior attachment device. When the locking sleeve is fully closed, it can not come open unexpectedly, and there are few moving parts to damage or fail. By design, the carabiner will provide the user with a durable, long-lasting attachment when compared with other connecting hardware. This is provided that it is properly cared for, maintained, and not subjected to non-specified uses.

In the event of a fall, tremendous forces can be generated and your life may depend on the condition of your personal fall protection equipment or system. Don't take any chances with one of the most important parts of that system, the carabiner. If there is any sign of damage, part fatigue, wear, or if the carabiner fails to pass the inspections of this manual, then replace this low cost component at once. Your life, your health, your happiness and well being are worth more than the cost of one carabiner.

6) **CARABINER LOCKING GATE POSITIONING:**

**Figs. 6.1 & 6.2** show a locking carabiner used as a connecting device for lifeline attachment to an approved anchor device. Never allow the locking gate of the carabiner to come in contact with the anchorage device or any other type of obstruction.

The gate is the weakest part of the carabiner. In the event of a fall, if the gate is jammed against the anchor point as shown in **Fig. 6.2**, the gate could fail; causing the carabiner to disengage from the anchor point.

Ensure the carabiner is used in the correct alignment position as shown in **Fig. 6.1**. This can be done by flipping the lifeline over the anchor point, or by detaching the carabiner, and re-attaching it in the correct position.

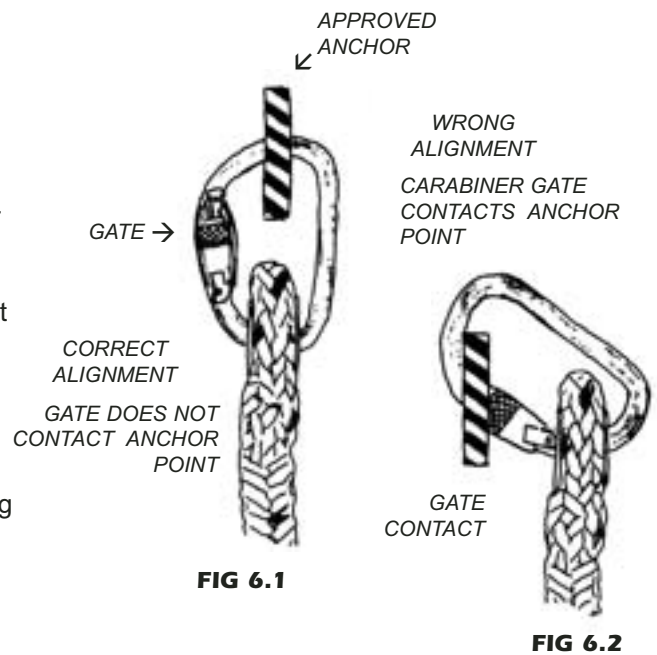

# SWING FALL HAZARD

Working Off-Center from the **Anchor Point** above will add length to the potential **Fall Hazard** exposure if not carefully monitored.

Use the Fall Arrestor Lifeline "**LIMITER KNOT**" to monitor the maximum allowable **Free Fall** or **Swing Fall** of 6 Ft.

With the Lifeline attached to the anchor point above and wearing your fall protection equipment, descend to the fall hazard leading edge, in this case, the roof edge. Standing directly below the anchor point above with no degree of angle or slack in the lifeline, measure out an additional 6 Ft. of lifeline and locate the "**LIMITER KNOT**" at that point.

As you work away from the anchor point above, at an angle, and while traveling along the perimeter edge of the fall Hazard, eventually the "**LIMITER KNOT**" will intersect the roof edge. This is the maximum allowable range of the anchor point above. If you were to fall from this point, you would experience a 6 Ft. Swing Fall, as shown below.

At this point, furthest from the anchor point above you have two options:

- 1) **ATTACH TO A DIFFERENT ANCHOR POINT CLOSER TO YOUR WORK AREA THAT DOES NOT CREATE A FALL HAZARD OF MORE THAN 6 FT.**
- 2) **TRAVEL UP SLOPE TO WORK.**

*WORKER POSITION BEFORE SWING FALL*

*POSITION AFTER SWING FALL:*

*WHEN WORKING OFF-CENTER FROM THE ANCHOR POINT ABOVE, A FREE FALL WILL SWING YOU BACK TO THE CENTER POINT BELOW THE ANCHOR.*

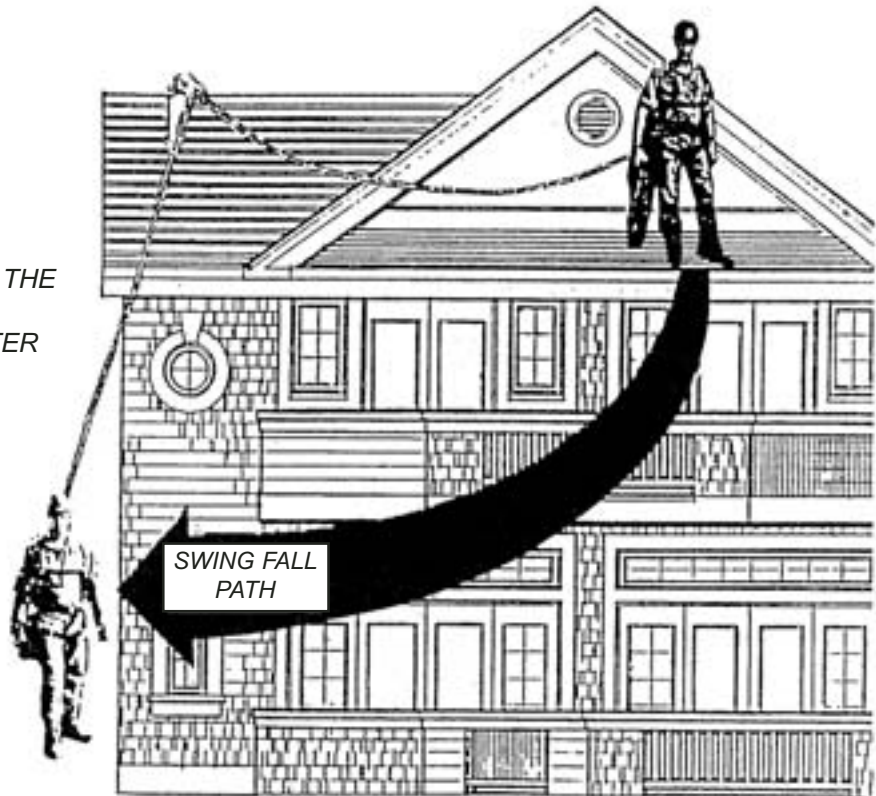

## **FREE FALL HAZARDS TO PLAN FOR:**

In the event you fall from an elevated work surface, there are two primary hazards you need to be aware of:

- 1) **STRIKING OBSTACLES BELOW YOU DURING A STRAIGHT OR FREE FALL.**
- 2) **CONTACTING THE GROUND BEFORE YOUR SAFETY EQUIPMENT ARRESTS THE FALL.**

Both of these types of hazards can be eliminated by planning ahead. You need to calculate the Total "**Length of Fall**" as shown on page 11 and remove obstacles below your work area.

# Body Harness Attachment Instructions

For Harness w/Nylon Ring Attachment - D-Ring Attachment - Shock Absorber Attachment  
Harness #6008 - Supplied with "Total Package"® is shown below.



Figure 1 - Before using any fall protection equipment, first read, or have explained to you, the information contained in the instructions provided with the equipment you are using. **Warning:** Improper use of safety equipment can cause serious injury or death.



Figure 2 - Hold the harness by the Nylon Ring or D-Ring depending on the style of harness you have. Shake out the harness to make sure that there are no tangles or twists in the straps.



Figure 3 - With shoulder strap buckles facing forward, put on the harness as you would a jacket. The D-Ring or Nylon Ring should be properly located on your back. Adjustments are easier if you get help when first setting up the equipment.



Figure 4 - Adjust both right and left side shoulder straps so they are in the position shown, with adjustment buckles facing forward.



Figure 5 - Attach chest strap to keep shoulder straps parallel and held in position so the harness cannot slip off in a fall.



Figure 6 - Attach leg strap buckles for a snug fit. Make sure that all straps are free of twists, tangles, or knots. The harness should fit comfortably.



Figure 7 - The area on the harness where the Nylon Ring or D-Ring is attached is called the Chafe Pad. It should be located just below your shoulders in the center of your upper back area as shown in the photo above. Adjust as needed for proper fit.



Figure 8 - Attach the carabiner through the fabric web loop at the end of the shock absorber or connecting lanyard. Then attach the Rope Grab Knot to the carabiner through the black plastic Rope Thimble. **BE SURE THE CARABINER IS LOCKED.**



Figure 9 - With Rope Grab Knot attached to shock absorber or connecting lanyard, the grab knot should be located below your waist and above your knee.

# Instructions for Attaching Lifelines, Lanyards and Shock Absorbers

Harness w/ Shock-Absorber



Figure 10

## Harness Parts

- Chafe Pad
- Nylon Ring
- Shock Absorber
- Connecting Lanyard
- Web Loop
- Locking Carabiner
- Rope Grab Knot

Harness #6013

D-Ring Harness



Figure 11

- Shoulder Strap
- D-Ring
- Locking Snaphook
- Nylon Web Lanyard
- Warning Label
- Leg Strap

Harness #6001

### Ensure Component Compatibility

Component compatibility means using equipment that is specifically designed to connect to each other without creating a potential hazard or equipment failure. Refer to compatibility charts on the back page of this manual and instruction/specification manuals for each type of equipment. When using Super Anchor Safety components, compatibility is "Factory Ensured" when instructions are complied with.

**Note:** When components mfg. by others are mixed with Super Anchor Safety equipment, component compatibility must be ensured by a "Qualified" person.

### Specified Hardware Connectors for Lanyards

Locking Snaphook: connect to D-Rings only (Fig 11).  
 Locking Carabiner: connect to D-Rings and web loops. DO NOT ATTACH TWO CONNECTORS TOGETHER!!!

### Warning

Do not attach a rope grab device or lifeline directly (Fig 13) to the D-Ring or Nylon Ring on the chafe pad. A connecting lanyard is required. Never attach a snaphook to the plastic eye thimble of the rope grab knot or lifeline. (Fig 14).

- Velcro Chest Strap
- Shoulder Strap Adjustment Buckles
- Work Positioning Side D-Rings (DO NOT USE FOR FALL ARREST)
- Locking Carabiner
- Rope Grab Knot
- Leg Strap Buckles
- Elastic Fabric Keepers



Figure 12

Harness #6011, #6013, #6037

Work Positioning Harness w/ Pelvic-supported side D-Rings

## WARNING! WRONG CONNECTIONS



Do Not attach rope grab to D-Ring or Nylon Ring.



Do not connect a snaphook through a Web Loop.

Figure 13

Figure 14

### Inspection Procedures

Safety equipment must be inspected by the users prior to each use, and employers should schedule regular examinations by a "competent" person to ensure that defective equipment is not in service.

Remove from service if any of the following defects are found:

- 1) Nylon webbing has any tears, rips, cuts, burns or chemical contamination.
- 2) Stitching is loose, frayed, cut, or two pcs of webbing are pulled apart.
- 3) Shoulder and leg strap buckles or D-Rings are bent, cut, or deformed.
- 4) Velcro chest strap will not stick to itself.
- 5) Warning and Serial number labels are missing.
- 6) Shock absorber is deployed or plastic cover is damaged or missing.
- 7) Chafe pad is damaged, elastic fabric keepers are missing.

**Note:** If the equipment is subjected to an "in service" fall, it must be removed immediately and inspected before returning to service.

# Length of Fall: "Sample Plan"

## Calculating the "Length of Fall"

The "Sample" plan below shows the factors that affect the distance traveled in a free fall. Your Personal Fall Protection system must comply with three basic requirements: 1) Limit the Free Fall distance to 6ft or less. 2) Arrest a free fall before impacting the ground, a lower level, or obstruction below, such as a lumber pile. 3) Reduce free fall impact load to 1800lbs or less. When using a shock absorbing lanyard as a component, the distance required to arrest a fall will be approx. 16.5 ft. If the distance between the Rope Grab Knot position (A), (approx. 24" above the working surface), to the nearest lower level, is less than your own "Job Specific" "Length of Fall Plan", then the length must be reduced so as to avoid impact in a free fall.

## Shock Absorbing and Nylon Web Lanyards

Shock absorbers reduce fall impact forces to 1800lbs or less, but add approx. 42" max. to the length of a fall. Once deployed or ripped out any amount, remove from service immediately. Nylon web lanyards do not absorb shock and will add only their specified length to the distance of the fall.

## Reducing the "Length of Fall"

The "Total Length of Fall" can be reduced in two primary ways: 1) Reduce the free fall distance to less than 6 ft. 2) Substitute a nylon web lanyard for a shock-absorber. When using a 18" nylon web lanyard part #6002 or #6009, the length of fall is reduced by 24", resulting in a total length of 14.5ft. instead of 16.5ft. NOTE: This substitution requires the use of Super Anchor® ARS 2x8, 2x12 or custom ARS series Fall Arrest Anchors which will absorb approx. 300-500lbs of force in a fall. A shock-absorber should only be substituted when the free fall distance, or other factors, can not be reduced.

## Adjusting the Lifeline for "Free Fall Distance"

With your harness on and the shock-absorber or nylon web-lanyard connected to the rope grab knot, connect the lifeline to the anchor point and descend in a straight line parallel with the rafter run, to the leading or perimeter edge (shown as point (A) on figure 16 below). Remove all slack from the lifeline and, pulling it tightly, move the rope grab knot into a position on the lifeline that is just above your knee. From that point, measure out the "Free Fall" length of your "Job Specific Plan" (must be 6ft or less). At that point, tie a limiter knot (as shown in the "Fall Arrestor"® lifeline manual) onto the lifeline. The excess line may be dangled over the edge or left on the working surface.

## Using the "Fall Arrest System"

Once you have adjusted the free fall distance for your own plan, using the "Limiter Knot", you may work in a 360° radius around the anchor provided no new fall hazards, such as a gable edge, are encountered. As you work to the right or left of the anchor points center, the grab knot will eventually intersect the "Limiter Knot" at the perimeter edge, limiting or preventing any further travel in that direction. At this point you have exceeded the "Working Range" of the anchor point. You have 3 options: 1) Move up-slope away from the perimeter edge, 2) Go back toward the anchor point center position, or 3) Move to a new anchor.

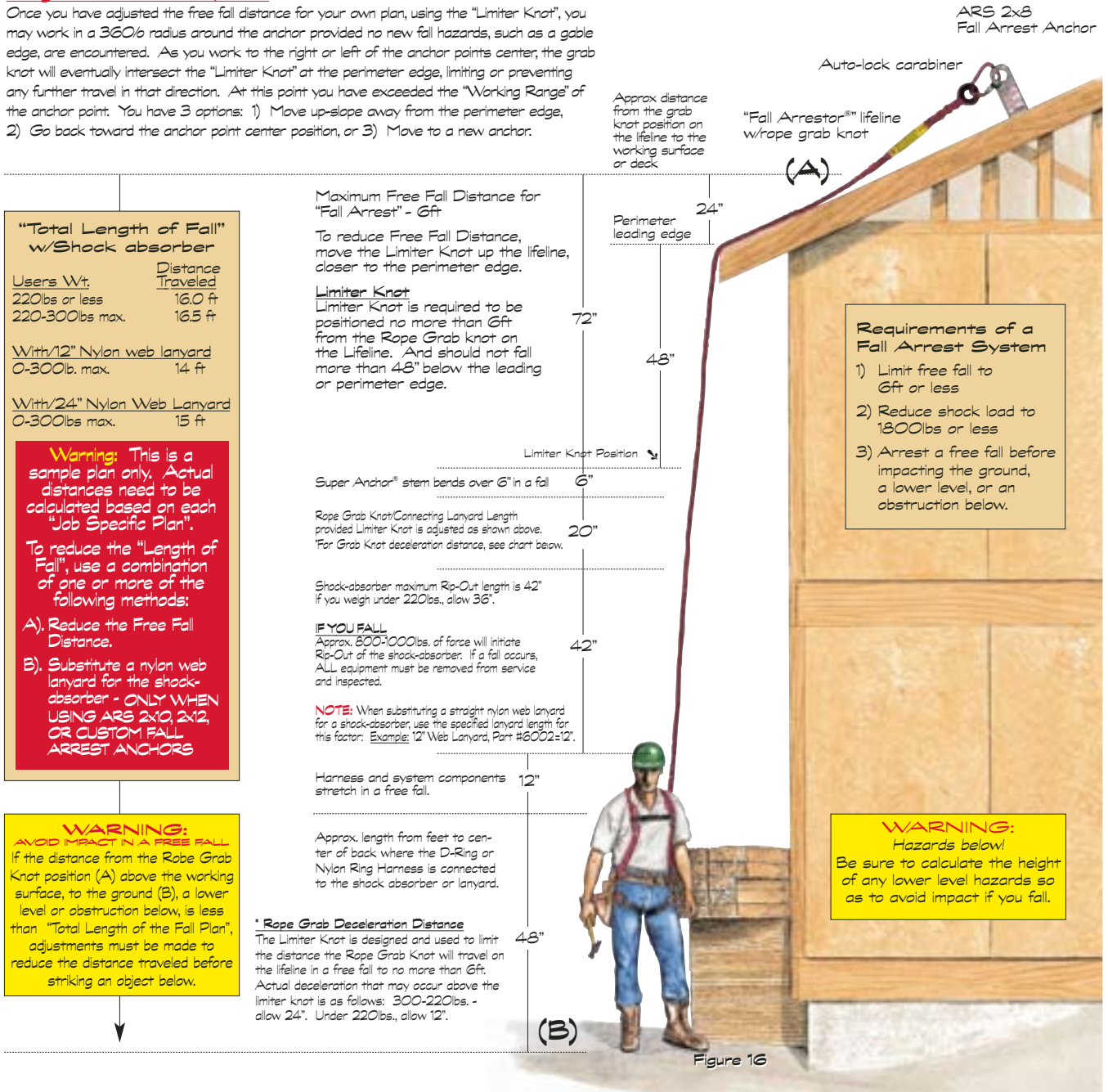

"Total Length of Fall" w/Shock absorber	
Users Wt.	Distance Traveled
220lbs or less	16.0 ft
220-300lbs max.	16.5 ft
With/12" Nylon web lanyard	
0-300lb. max.	14 ft
With/24" Nylon Web Lanyard	
0-300lbs max.	15 ft

**Warning:** This is a sample plan only. Actual distances need to be calculated based on each "Job Specific Plan". To reduce the "Length of Fall", use a combination of one or more of the following methods:

- A). Reduce the Free Fall Distance.
- B). Substitute a nylon web lanyard for the shock-absorber - ONLY WHEN USING ARS 2x10, 2x12, OR CUSTOM FALL ARREST ANCHORS

**WARNING:** AVOID IMPACT IN A FREE FALL. If the distance from the Rope Grab Knot position (A) above the working surface, to the ground (B), a lower level or obstruction below, is less than "Total Length of the Fall Plan", adjustments must be made to reduce the distance traveled before striking an object below.

Maximum Free Fall Distance for "Fall Arrest" - 6ft

To reduce Free Fall Distance, move the Limiter Knot up the lifeline, closer to the perimeter edge.

**Limiter Knot**  
Limiter Knot is required to be positioned no more than 6ft from the Rope Grab knot on the Lifeline. And should not fall more than 48" below the leading or perimeter edge.

Super Anchor® stem bends over 6" in a fall 6"

Rope Grab Knot/Connecting Lanyard Length provided Limiter Knot is adjusted as shown above. For Grab Knot deceleration distance, see chart below. 20"

Shock-absorber maximum Rip-Out length is 42" if you weigh under 220lbs., allow 36". 42"

**IF YOU FALL**  
Approx. 800-1000lbs. of force will initiate Rip-Out of the shock-absorber. If a fall occurs, ALL equipment must be removed from service and inspected.

**NOTE:** When substituting a straight nylon web lanyard for a shock-absorber, use the specified lanyard length for this factor. Example: 12" Web Lanyard, Part #6002=12".

Harness and system components stretch in a free fall. 12"

Approx. length from feet to center of back where the D-Ring or Nylon Ring Harness is connected to the shock absorber or lanyard. 48"

**\* Rope Grab Deceleration Distance**  
The Limiter Knot is designed and used to limit the distance the Rope Grab Knot will travel on the lifeline in a free fall to no more than 6ft. Actual deceleration that may occur above the limiter knot is as follows: 300-220lbs. - allow 24". Under 220lbs., allow 12".

**Requirements of a Fall Arrest System**

- 1) Limit free fall to 6ft or less
- 2) Reduce shock load to 1800lbs or less
- 3) Arrest a free fall before impacting the ground, a lower level, or an obstruction below.

**WARNING:** Hazards below! Be sure to calculate the height of any lower level hazards so as to avoid impact if you fall.

Figure 16

# Compatibility Chart / Nylon Ring / D-Ring Harnesses

Harness Model #6008 & #6013  
w/shock absorber  
#6013 also has side D-Rings

Web Lanyard  
connected to  
Nylon Ring  
w/carabiner



**NOTE:** This configuration is used when the "length of fall" does not permit the use of a shock absorber which adds approx. 42" to the length of fall. When the web lanyard is not used it must be removed from the harness.



Nylon Ring Harness  
Part # 6007

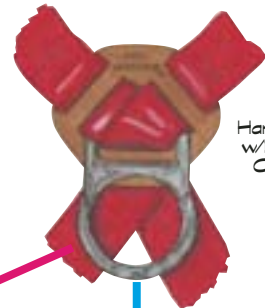

Harness Models  
w/Back D-Ring  
Configuration  
# 6001  
# 6011  
# 6035  
# 6036  
# 6037  
# 6038

Internal Shock  
Absorber  
w/Carabiner  
#6026

Web Lanyard  
w/Carabiner  
18' #6009  
24' #6012  
48' #6022  
60' #6024  
72' #6017

72' Shock  
Absorber  
w/Carabiner  
#6028

Integral Shock  
Absorber  
w/Carabiner  
#6026

Shock  
Absorber  
w/Snaphook &  
Small D-Ring  
#6018

Integral Shock  
Absorber  
w/Snaphook  
#6025

Web Lanyard  
w/Snaphook  
18' #6002  
24' #6006  
48' #6021  
60' #6023  
72' #6014

72' Shock  
Absorber  
w/Snaphook  
#6027

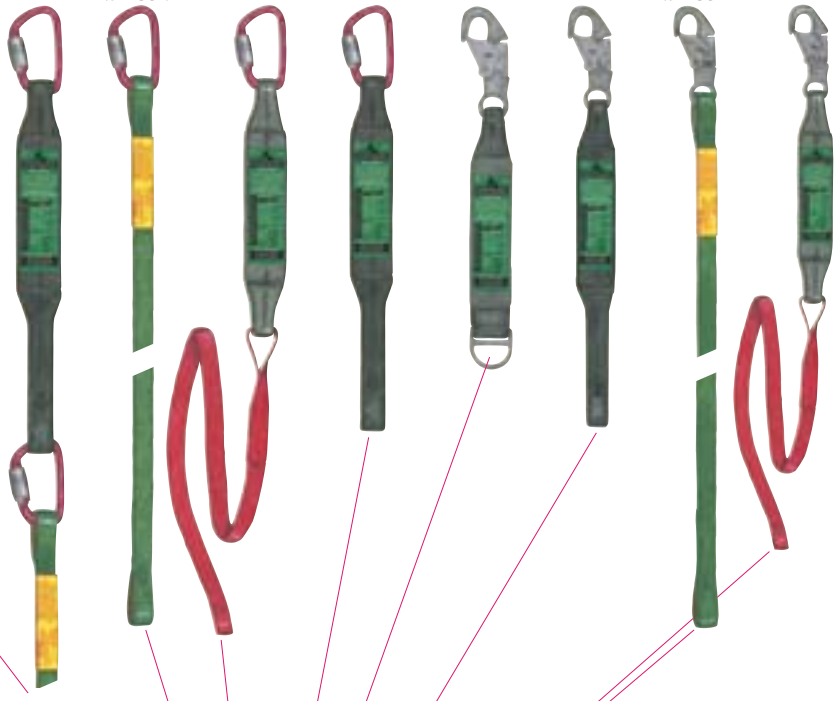

Accessory  
web lanyard  
attached to  
absorber  
w/carabiner

## NON-COMPATIBILITY

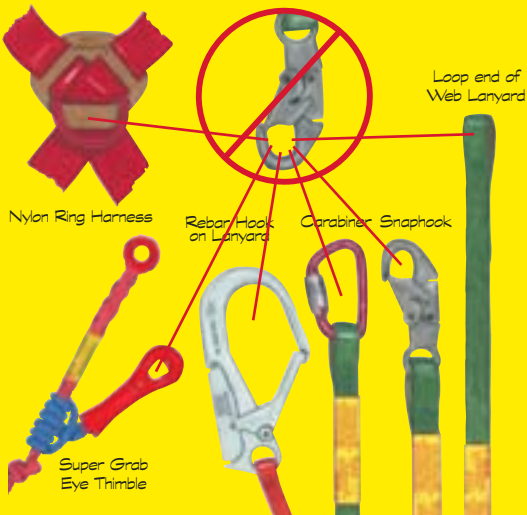

Loop end of  
Web Lanyard

Nylon Ring Harness

Rebar Hook  
on Lanyard

Carabiner Snaphook

Super Grab  
Eye Thimble

FALL  
ARRESTOR®  
Super grab  
w/Carabiner  
Part #4015

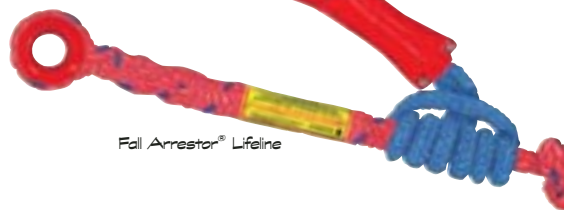

Fall Arrestor® Lifeline



Work Positioning Harness  
Side D-Ring  
#6011, #6013 & #6037

**Note:**  
For a complete list of  
Harness accessories,  
please request a catalog

Safety equipment manufactured by **SUPER ANCHOR SAFETY**  
Complies with ANSI-A10.14.91 and OSHA 1926.500-503

# **SUPER ANCHOR SAFETY**

8522 – 216 th. Street SE Woodinville, WA 98072-8009

Phone: (425) 488-8868 Fax: (360) 668-1717

---

## **User's Daily Checklist:**

After you have received instruction and training regarding the use of the personal fall protection equipment supplied in the **“Total Package”**, you will need to do the following inspections and observe the following procedures EACH TIME before use:

- I** Inspect all of the equipment you will be using, including the anchor point for damage, fabric contamination, wear and tear. **DO NOT USE** defective equipment. Refer to the inspection part of the equipment instructions.
- II** Before you enter an area where a fall hazard exists, be sure the anchorpoint meets U.S. Dept. of Labor standards, and is compatible with the manufacturer's instructions for use.
- III** Be sure to calculate the Swing Fall Hazard and the total freefall distance. Remember, using a shock absorbing lanyard will add up to 42” to the fall.
- IV** In the event of a fall, you must replace all of the equipment that is in use at the time of the fall.

### **Including but not limited to:**

Full Body Harness and Shock Absorber attached  
Lifeline / Rope Grab System  
Carabiners  
Anchor Point

- V** Do not remove the shock absorber from the body harness and attach a different component, or attach any hardware to the Nylon Loop located on the chafe pad of the harness back.

# SUPER ANCHOR®

## FALL ARREST ANCHOR

U. S. Patent No. 5,370,202

**SUPER ANCHOR®** Fall Arrest Anchors lead the industry in cost-effective, easy-to-install personal fall protection tie-off points; we call them Anchors.

OSHA standards require lifelines to be secured to an anchorage point capable of supporting 5,000 lbs. and be able to sustain a 220 lb. free fall of 6 Ft. Our Fall Arrest Anchors exceed those requirements, provided you install them and use them according to our specifications.

Our patented anchor design, installed along with the flashing system, provides tie-off points that are accessible for use by all trades exposed to fall hazards, from the framing stage up through completion of the project. In addition, anchors may be left in place for use by service companies. You will find Super Anchors easy to retro-fit to any existing structure.

Super Anchors are made to last, from domestic 14 ga. Stainless Steel, and manufactured in the U.S. Standard Anchor "Combi-Packs" come with a Santoprene Flashing, Stem Cover and Tether Strap, Fastener Kit, Warning Label, and our comprehensive 6 page Instruction Manual.

### STANDARD SIZES:

Available in 2 standard sizes to fit all common wood rafters/trusses: **ARS 2x8** for 2x4, 2x6, and 2x8; and **ARS 2x12** for 2x10 and 2x12 rafters.

### CUSTOM SIZES:

In addition to our standard sizes, we custom build for attachment to Glu-Lam Beams, Wood I-Joists, Steel I-Beams, Bar Joists, Steel Trusses, etc. Simply fill out our Custom Anchor Worksheet for each size anchor you need, then fax us the work sheet, and we'll provide you with a custom quote and a list of distributors.

So, whether you need standard or custom anchors, why tie-off to anything less than a Super Anchor Fall Arrest Anchor? If you fall, your life may depend on it.

And why not try our Fall Arrestor Lifeline/Rope Grab System shown at right? It is component compatible with all our anchors and meets current Federal OSHA standards for lifelines.



## The UNIVERSAL ANCHOR

**A HEAVY-DUTY REUSABLE ANCHOR POINT THAT PROVIDES FALL PROTECTION FOR ALL TRADES.**

- 11 Ga. SST surface mounted. Includes #2009 Fastener Kit and Instructions.
- Mounts to either plywood or OSB board sheathing.
- For use on flat surfaces or pitched roofs up to a 12/12 Pitch.
- Two additional Fastener Kits are available for Fall Arrest or Work Positioning applications.
- Fully compatible with our **FALL ARRESTOR®** Lifeline/Rope Grab and **"TOTAL PACKAGE®"** Lifeline and Harness System.



# SUPER ANCHOR®

**AT LAST, A VARIETY OF INNOVATIVE, RE-USABLE FALL PROTECTION ANCHORAGE DEVICES THAT PROVIDE SAFETY FOR FRAMERS, ROOFERS, SIDERS, PAINTERS AND MANY OTHER TRADES.**

*All products feature easy installation, comply with OSHA Fall Protection Standards, and include instructions.*

*Whatever your trade, we have an Anchorage Solution for you.*

## MOVEABLE ARS ANCHOR

Attaches to standard framing. Simply place over rafter or truss and insert Detent Pin through bolt hole closest to the bottom of the rafter. Teko Nails may be used to stabilize the anchor during use. Great for remodeling and reroofing projects.

- 11 Ga. SST. Powder Coated Red, with SST Detent Pin.
- ARS 2x8 – Fits 2x4, 2x6, 2x8 Rafters.
- ARS 2x12 – Fits 2x10, 2x12 Rafters.



## ARS-5K (4-Pack)

- The ARS 5-K is a lightweight, reusable anchor that can be used in both Fall Arrest and Work Positioning applications.
- Made of 18 Ga. SST, the legs can be bent for use on flat surfaces or on roofs up to a 12/12 Pitch.
- Includes 4 Anchors, 4 Fastener Kits, 1 Nut Driver, and Instruction Manual.
- Replacement Fastener Kit – Part #2009 also available.



## ARS-3K (1/2 Rack)

- The ARS 3-K is an economical, Non-Reusable Ridge-Mounted anchor for Fall Restraint/Work Positioning applications. Must be used with harness fitted with Shock Absorbing Lanyard.
- Installs by positioning anchor at the ridge, aligning legs over the rafter center, and securing all 10 factory fasteners through the roof sheathing into the rafter. Anchor should be removed and destroyed after use or bend over anchor stem and roof over anchor when work is completed.
- Made of 16 Ga. steel, the legs are pre-bent to a 5/12 pitch and are easily adjustable to different pitches. Maximum allowable pitch is 8/12.
- Includes 12 Anchors, 12 Nail Sets of 10 per set, and Instruction Manual.

Mfg. by: **SUPER ANCHOR SAFETY** • 8522 216th Street SE • Woodinville, WA 98072-8009  
Phone **(425) 488-8868** or Fax us at **(360) 668-1717**  
Visit Our Website at [www.superanchor.com](http://www.superanchor.com)

# FALL ARRESTOR®

## PERSONAL LIFELINE/ROPE GRAB SYSTEM INSTRUCTION / SPECIFICATION MANUAL

### USER COMPLIANCE

Fall Arrestor Lifeline/Rope Grab System is designed to be used with other safety components manufactured by SUPER ANCHOR SAFETY. The "User" will ensure component compatibility with body harnesses, lanyards, shock absorbing devices, attachment hardware, and anchorage devices.

Each "User" is required to receive training and instruction from this manual regarding the **Use, Inspection, and Maintenance** of the Fall Arrestor Lifeline System before use.

"User" is any person who purchases, employs others, trains others in safety, or uses this equipment for fall protection.

### SPECIFICATIONS FOR USE:

The Fall Arrestor Lifeline/Super Grab is designed to be used by one person as a fall arrest or work positioning system with additional fall protection equipment; a body harness, shock absorber, lanyard and anchorage device which are also Mfg. by SUPER ANCHOR SAFETY and are referred to in this manual using our part numbers.

### LIFELINE SPECIFICATIONS:

The 5/8" diameter Fall Arrestor lifeline is made from 12 strand poly-olefin line rated for 11,600 lbs and is colored red with a blue tracer. Special Coatings reduce abrasion, and water absorption is less than 2%. Lifelines are furnished in 30 ft., 50 ft., and Custom lengths.

### SUPER GRAB - ROPE GRAB / DECELERATION DEVICE:

The Fall Arrestor lifeline system utilizes the Super Grab as a fall arrestor, deceleration device which locks onto the lifeline when a force is exerted in any direction. The 7/16" grab rope is made from blue colored double braided line rated for 7,370 lbs. It is coated to reduce abrasion and water absorption. The Super Grab is easily adjusted for varying fall hazards by moving the grab knot position on the lifeline. The Super Grab is a component of the lifeline system and comes pre-installed. It should not be removed from the lifeline except for replacement. (See pages 3-4 for instructions and details.)

### ROPE SPlice AND EYE THIMBLE:

The lifeline attachment end is spliced using a synthetic eye thimble. A locking type carabiner is used to connect the lifeline to the anchor point. When factory supplied snaphooks are fitted onto the lifeline, the eye thimble will have an access cut. See **Fig. 3.1, Pg. 18**. The thimble is designed to break, crack, or deform when subjected to a free fall or other extreme force.

### TERMINATION KNOT AND LIFELINE TERMINATION END:

The termination knot is required to be tied 12.0" from the "B" end of the lifeline to prevent accidental disengagement of the grab knot. See **Fig. 1, End "B"**. Lifelines are terminated using a hot knife and finished with a colored adhesive shrink tube; black for 30 ft. lines and red for 50 ft. lines.

### WARNING AND SERIAL NUMBER LABEL:

The yellow warning label is protected with clear PVC shrink tube attached to the eye splice taper. The Date of Mfg., serial number, and the lifeline length are displayed.

**REMOVE FROM SERVICE IF THE PVC SHRINK TUBING OR LABEL ARE MISSING, OR UNREADABLE.**

### LIMITER KNOT:

The limiter knot is not required to arrest a fall but is used as a gauging device for free fall distance and hazard exposure. See **Fig. 5, Pg. 20**. Use no other type of knot. The limiter knot position is moved by untying and re-tying the knot in the desired position on the lifeline.

## COMPLIES WITH ANSI A10.14.91

**Fig. 1** Fall Arrestor Lifeline w/Super Grab

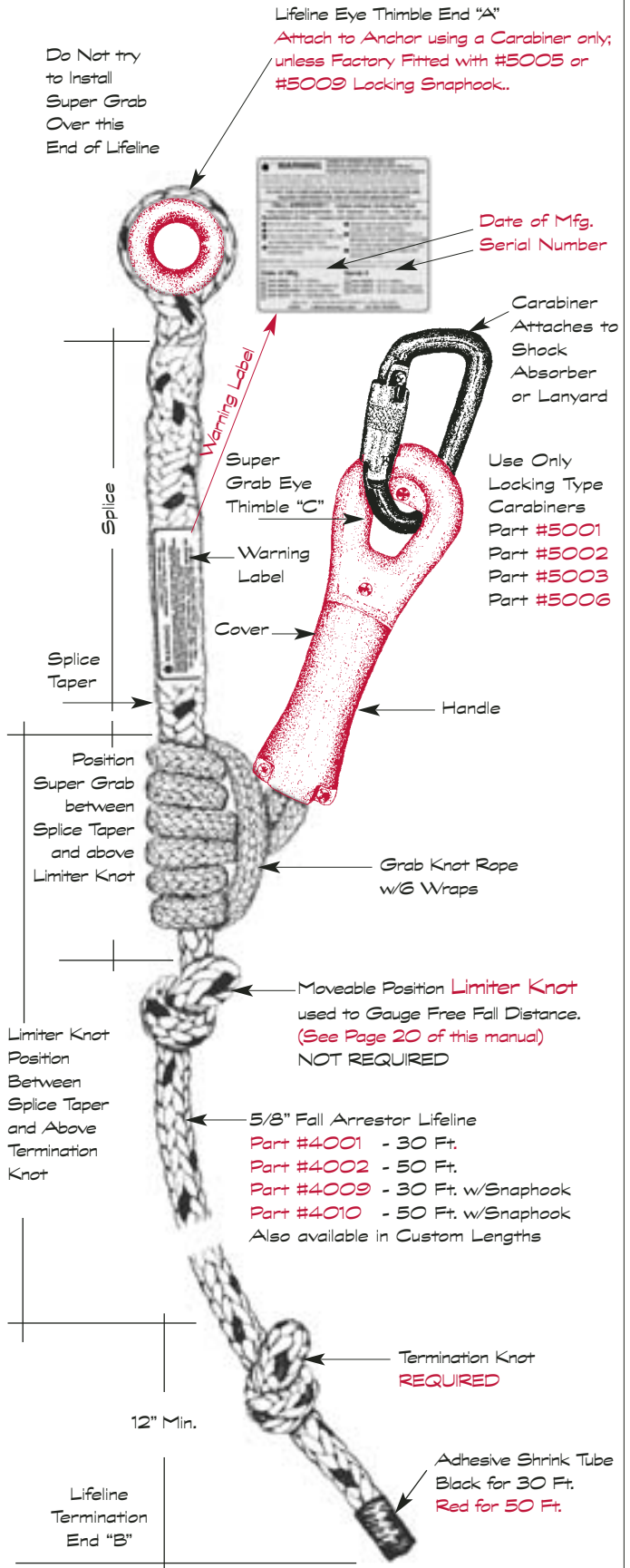

### TRAINING AND INSTRUCTION:

The contents of this manual address only the "Fall Arrestor / Super Grab" system and do not represent the entire training that a user may need in order to use fall protection equipment safely. If you do not understand how to use this equipment, you must receive instruction from someone who is competent or qualified to teach you. See **Pg. 21** for definitions. Refer to training requirements in OSHA 1926;503.

### COMPONENT COMPATIBILITY:

The equipment addressed by this manual is compatible with other equipment Mfg. by SUPER ANCHOR SAFETY, provided all instruction and compatibility charts for additional components are followed.

### COMPONENTS BY OTHER EQUIPMENT MANUFACTURERS:

The purchaser or user must ensure component compatibility with the Fall Arrestor system when using equipment manufactured by others. Unforeseen hazards created by improper connections or incompatible equipment could result in serious injury or death.

### COMPLIANCE AND TESTING:

The Fall Arrestor<sup>®</sup> Lifeline / Super Grab complies with OSHA standards for Personal Fall Protection equipment and "Non-mandatory" guidelines of Sub-Part M, appendix B. ANSI certification is not required by OSHA for use in the United States. It is the responsibility of the user to ensure that the compliance and testing noted in this manual are acceptable under the industrial safety standards in your area. Certification is ongoing. Additional certification not shown here will be noted in future revisions of this manual, and may be available by calling our office.

### ADDITIONAL INSTRUCTION

#### Spanish Language Manuals:

Lifeline Manual - Rev. 2001  
Super Grab Manual - 2001  
2x8 Anchor Manual  
Universal Anchor Manual  
ARS 3-K Anchor Manual

#### Availability:

Phone Mfg. Office  
(425) 488-8868  
Download off Website  
www.superanchor.com

#### Compliance:

OSHA 1926.502 (d)(16)(iv)  
CAL-OSHA CSO 1670(m)

#### Test Standards:

Subpart M - Appendix B (I)(b)(c)(d)(e)  
ANSI A10.14.91

### THE FOLLOWING INSTRUCTIONS APPLY ONLY TO THE USE OF THE SUPER GRAB WHEN USED ON THE FALL ARRESTOR<sup>®</sup> LIFELINE/ROPE GRAB SYSTEM.

### VISUAL INSPECTION REQUIRED BEFORE EACH USE:

**2.a)** The Lifeline and Super Grab must not have any broken, cut, burned, worn, or otherwise damaged rope strands. The surfaces of the ropes shall be free of any loose materials such as dirt, sand, mud, sawdust, or other types of materials. The Rope surfaces shall be free of any kind of petroleum or chemical contaminants. If this type of damage occurs, **REMOVE FROM SERVICE**. Small patches of tar and caulking may be removed with warm water and mild detergents ONLY. Do not use any cleaning solvents, agents, acids, gasoline, etc. on the rope or Super Grab cover. This may seriously damage the components.

**2.b)** Warning Labels and the synthetic Rope Eye Thimble must be in place on the Lifeline. The Eye Thimble will break apart or elongate when the system is subjected to a free fall or other extreme force; such as towing or hoisting materials. The entire system; Lifeline, Super Grab, and carabiner, and any other components being used for Fall Protection, must be **REMOVED FROM SERVICE** if a fall has occurred, or if the lifeline has been used for a non-specified purpose. See OSHA 1926;502 (d)(19).

**2.c)** As shown in **Fig. 2.2** below, if the Rope Eye Splice has opened up and there is more than 1/4" between the splice joint and the synthetic Rope Eye Thimble, then the splice may be coming loose or the rope may have been subjected to an extreme force. **REMOVE FROM SERVICE IMMEDIATELY. WARNING: DO NOT TRY TO RE-SPLICE OR REPAIR THE SPLICE.**

**Fig. 2.1**

Missing Parts

Eye Thimble Missing

Clear Shrink Tube Missing

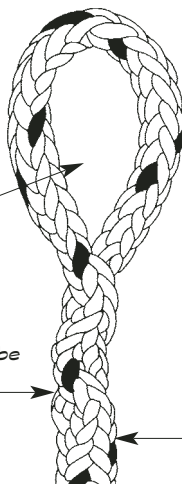
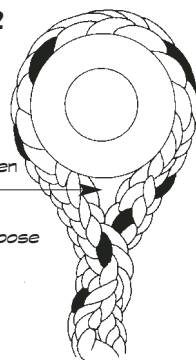

**Fig. 2.2**

Splice Defect

Gap Between Rope

Thimble is Loose



**Fig. 2.3**

Fall Impact or Abuse

Thimble Out of Round or Elongated

Thimble Crack

Rope is Stretched or Gap Between Sides

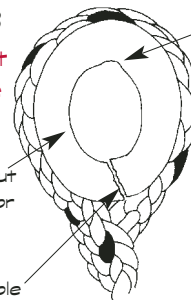

**Fig. 2.4**

Damaged Thimble, Splice, or Rope

Dent May Be Caused from Carabiner Stress

Broken or Cracked Thimble

Broken / Cut Strands Anywhere in the Lifeline

Abraded or Cut Strands

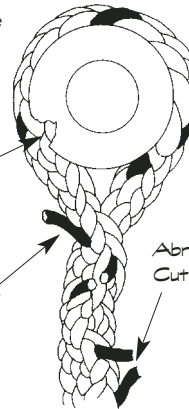

**NOTE:** LIFELINES FITTED WITH SNAPHOOKS WILL HAVE A CLEAN CUT THROUGH THE EYE THIMBLE.

### CARABINER / SNAPHOOK INSPECTION:

**2.d)** **Carabiners** shown in **Fig. 3.2, Pg. 18**, are equipped with threadlock or auto locking devices to prevent the gate from opening. Inspect the gate and body for any signs of bending or damage. The gate and locking device must open and close easily. Removal of debris or contaminants may be required. The autolock is opened by rotating the barrel. A spring returns the barrel to the closed position.

**2.e)** **Snaphooks** shown in **Fig. 3.1, Pg. 18**, are equipped with 2 locking devices to prevent the gate from opening. Both the Snaphook gate and Thumb Lock must be depressed to open, while closing is automatic by releasing the locking mechanisms. Inspect the snaphook gate and body for damage or deformation. Check the locking devices for smooth function.

Remove any Snaphooks / Carabiners that do not pass inspection.

**DO NOT ATTEMPT TO DISASSEMBLE, STRAIGHTEN, OR REPAIR DEFECTIVE CONNECTORS.**

**LIFELINE ATTACHMENT TO ANCHORAGE POINT:**

**Carabiner & Snaphook - Positioning/Alignment**

The locking mechanisms of the snaphook thumb lock and gate, and the carabiner gate, must not come into contact with the anchor point, lifeline, or any other obstruction that may cause it to jamb, bend, or unlock during use. The correct connector to anchor positions are shown in below in **Figs. 3.1 & 3.2.**

**WARNING: IT MAY BE NECESSARY TO MANUALLY ROTATE, OR DISCONNECT AND RECONNECT THE SNAPHOOK OR CARABINER, TO PREVENT THE LOCKING GATES FROM ENGAGING THE ANCHOR AS SHOWN BELOW IN Figs. 3.3 & 3.4.**

**ATTACHING LIFELINE TO ANCHOR POINT  
ARS 2X8 SHOWN**

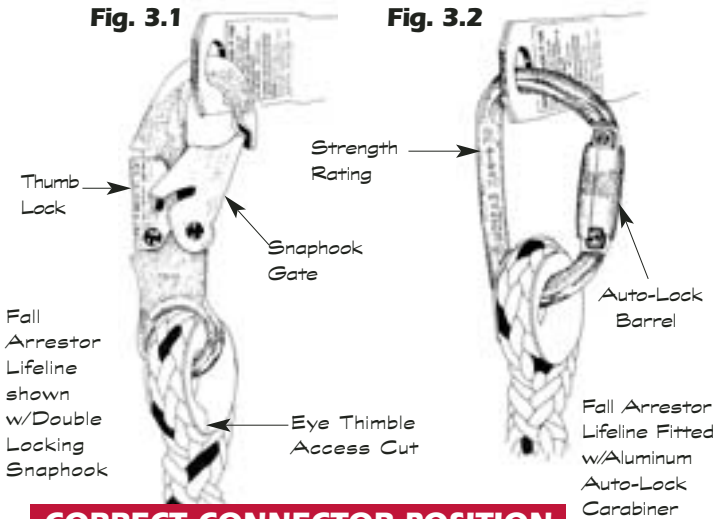

**CORRECT CONNECTOR POSITION**

**SNAPHOOK AND CARABINER GATES IMPROPERLY  
LODGED AGAINST ANCHOR ATTACHMENT HOLE**

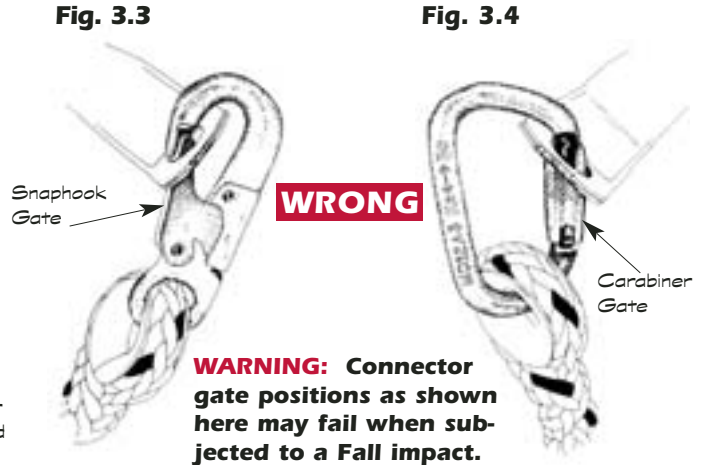

**WARNING: Connector gate positions as shown here may fail when subjected to a Fall impact.**

**DO NOT ALLOW THE GATES OR LOCKING DEVICES TO COME IN CONTACT WITH ANCHOR OR OTHER OBSTRUCTIONS. CONNECTOR MUST ROTATE FREELY WHEN ATTACHED.**

**FALL ARRESTOR <sup>®</sup> SUPER GRAB - INSTRUCTIONS FOR USE**

**SPECIFICATION OF USE:**

When subjected to a free fall of no more than 6 ft., having a maximum weight of 300 lbs. (combined wt. of a single worker and tools or equipment), the Super Grab will decelerate no more than 12" before arresting a fall.

**DESCRIPTION OF COMPONENTS:**

Super Grab utilizes the Triple Sliding Hitch, or Prussic knot principle of grabbing the lifeline when a force is exerted in any direction on the eye thimble end of the cover. The red ABS plastic cover houses the grab rope and is cosmetic only and should not be removed. The grab rope is wrapped around the lifeline and forms a continuous loop that is swaged using an aluminum oval contained inside the cover. Made from 7/16" Polyester / Nylon material, the loop exceeds 7300 lbs. average tensile strength.

**COVER:**

The plastic cover is designed to crack, break in half, or deform when subjected to a fall impact which requires removal from service. This allows for easy visual inspection before each use. Improper storage, non-specified use, or stepping on the cover may also result in damage.

**GRAB ROPE:**

The grab knot rope must have 6 wraps around the lifeline as shown in **Fig. 3.5.** Do not untie the grab knot or use if there are less than 6 wraps. As a safety feature, the cover's length dimension will prevent the grab rope wraps from unintentional disengagement. Inspect rope wraps where it enters the cover and remove from service if any strands are cut, abraded, or damaged.

**CONNECTING HARDWARE:**

The eye thimble end of the cover is sized to accept ONLY A LOCKING TYPE CARABINER as supplied by SUPER ANCHOR SAFETY.

Type	Model Number	Strength Rating
Auto-Lock Steel	5001	8990 lbs.
Threadlock Steel	5002	8990 lbs.
Threadlock Aluminum	5003	5395 lbs.
Auto-Lock Aluminum	5006	6744 lbs.

**DO NOT ATTACH A CONNECTOR TO ANY PORTION OF THE GRAB ROPE. THIS MAY INTERFERE WITH ITS NORMAL FUNCTION.**

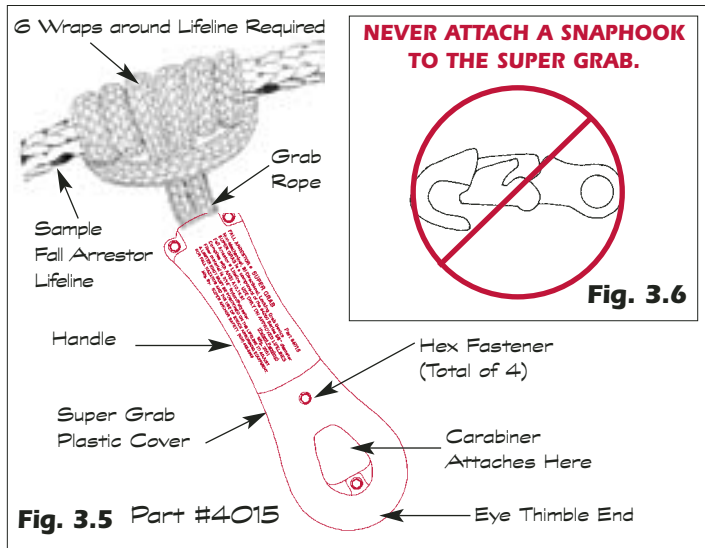

**Fig. 3.5** Part #4015

**Use only a carabiner to attach the Super Grab to a web loop end of a shock absorber or a connecting lanyard.**

**CARABINERS MANUFACTURED BY OTHERS:**

For carabiners not specified in this manual, component compatibility must be ensured by the user.

**DO NOT USE NON-LOCKING TYPE CARABINERS OR CARABINERS THAT HAVE A GATE OPENING THAT DOES NOT ALLOW EASY ATTACHMENT TO THE EYE THIMBLE.**

**DO NOT FORCE A CARABINER OVER THE EYE THIMBLE.**

**WARNING: DO NOT ATTACH THE SUPER GRAB DIRECTLY TO A BODY HARNESS AND DO NOT CONNECT A CARABINER TO ANOTHER CARABINER OR SNAPHOOK.**

**NEVER ATTACH A SNAPHOOK TO THE SUPER GRAB COVER OR ANY PORTION OF THE ROPE.**

#### ATTACHING SUPER GRAB REPLACEMENT PART #4015:

If the Super grab is damaged as a result of abuse and the lifeline has not been subjected to a fall or other extreme force, the Super Grab component may be replaced. The grab rope is pre-wrapped around a small section of the 5/8" diameter "Fall Arrestor" lifeline. Do not remove the sample rope until the receiver lifeline is prepared, and do not attempt to re-wrap the grab rope if it comes undone.

#### PREPARING THE LIFELINE:

Remove the existing grab knot by undoing the "Limiter and Termination" knots. See Fig. 1, Pg. 16. Slide the grab knot off the termination end "B". Install the replacement "Super Grab" by inserting the lifeline termination end through the 6 wraps, displacing the sample piece of rope. See Fig. 3.5, Pg. 18. Re-tie the "Termination and Limiter" knots on the lifeline with the Super Grab positioned between the splice taper and the limiter knot. See Fig. 1, Pg. 16.

The grab rope should fit snugly around the lifeline and should lock on the lifeline rope when a force is exerted on the thimble end "C" of the Super Grab. Be sure to check for proper function before use.

**DO NOT INSTALL OVER EYE THIMBLE END, OR ON SPLICE TAPER. USE ONLY ONE SUPER GRAB PER LIFELINE AND DO NOT INSTALL ON LINES THAT ARE NOT CERTIFIED FOR USE WITH THE SUPER GRAB.**

#### LIFELINE INSPECTION FOR GRAB KNOT REPLACEMENT:

Ensure that the lifeline passes the inspection procedures in this manual as well as the aging and removal from service recommendations on page 21. Additional inspection may be required by the purchaser or user.

**DO NOT INSTALL A NEW SUPER GRAB ONTO A LIFELINE THAT DOES NOT PASS INSPECTION, IS OUT OF SERVICE, OR HAS BEEN SUBJECTED TO A FALL OR OTHER FORCE.**

#### WHEN A FALL OCCURS:

In the event the Super Grab is subjected to a fall impact, it must be removed from service and disposed of in a way that prevents it from being used again. See Pg. 21. **WARNING: IN THE EVENT OF A FALL, DO NOT GRAB HOLD OF THE GRAB KNOT. THIS MAY RESULT IN A FAILURE TO LOCK ONTO THE LINE.**

#### INSPECTION:

Inspect the Super Grab before each use. Look for signs of cracking, deformation of the eye thimble end, missing attachment screws, or damage to the grab rope portion; such as cut or abraded strands.

#### LIMITATION OF USE:

Use only for personal fall protection. Super Grab is not intended for recreational use, hoisting, towing, or securing loads.

**DO NOT USE FOR VERTICAL OVERHEAD LINE IN CALIFORNIA. USE AS VERTICAL OVERHEAD LINE IN OTHER STATES ONLY WHEN USED WITH LIMITER KNOT.**

#### HORIZONTAL USE:

OSHA requires that horizontal lines be designed and engineered by a "Qualified Person" 1926.502 (d)(8) and that connection with a vertical line is accomplished using a device that locks in both directions (d)(7). The Fall Arrestor system may be used for the "Vertical" or Connecting lanyard portion of a horizontal line system when a compliance certificate or other supporting engineering documentation is supplied by a "Qualified Person", but may not be used as the horizontal component which may require stronger rope and connectors. **DO NOT ATTACH THE SUPER GRAB TO A HORIZONTAL LINE SYSTEM WITHOUT FACTORY AUTHORIZATION FROM SUPER ANCHOR SAFETY.**

The grab rope may not be compatible with the horizontal line and could fail if subjected to a fall.

#### HORIZONTAL LINE COMPONENTS:

Custom length and larger diameter lines are available as well as custom sized Super Grabs for horizontal use. Inquire by contacting your distributor or our office.

#### NON-COMPATIBILITY - Fig. 4.1

Do not link two connectors together "A" and "B" and do not attach connectors to a vertical line, "C". Do not tie a limiter knot between the anchor point and the Super Grab "D".

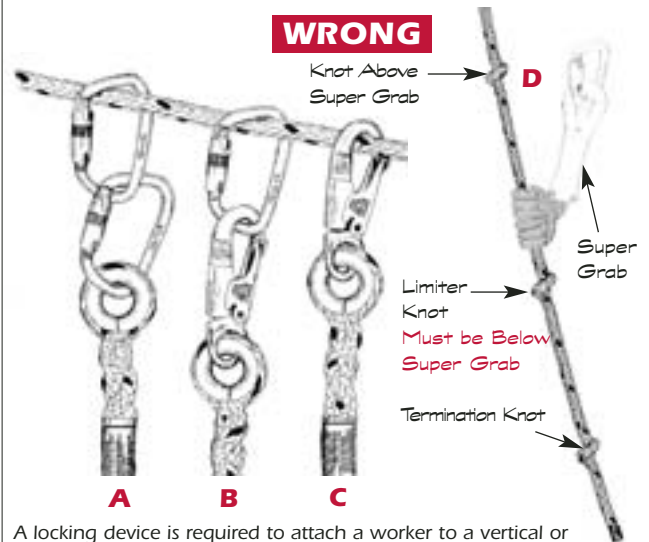

A locking device is required to attach a worker to a vertical or horizontal line. **Connections shown (A,B,C) will disengage if the anchor or line fails.**

#### NON-COMPATIBILITY - Fig. 4.2

Do not link lifelines together using connecting hardware "E" by hand tied knots "F", or by tying a line through the eye splice "G". Lifelines of a continuous length should be used.

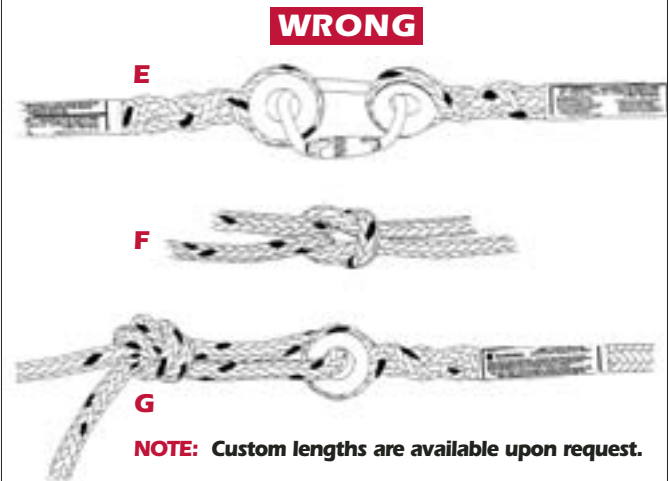

#### NON-COMPATIBILITY - Fig. 4.3

Do not tie a lifeline around an object or to framing "H". Do not tie a lifeline to an anchor. "I" Use only a compatible anchor point.

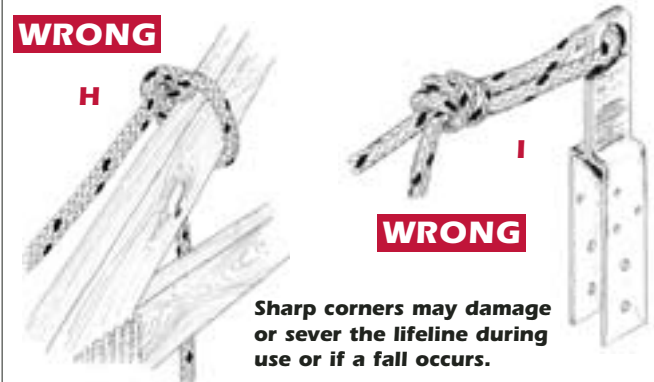

## ADJUSTING LIFELINE ROPE GRAB POSITION:

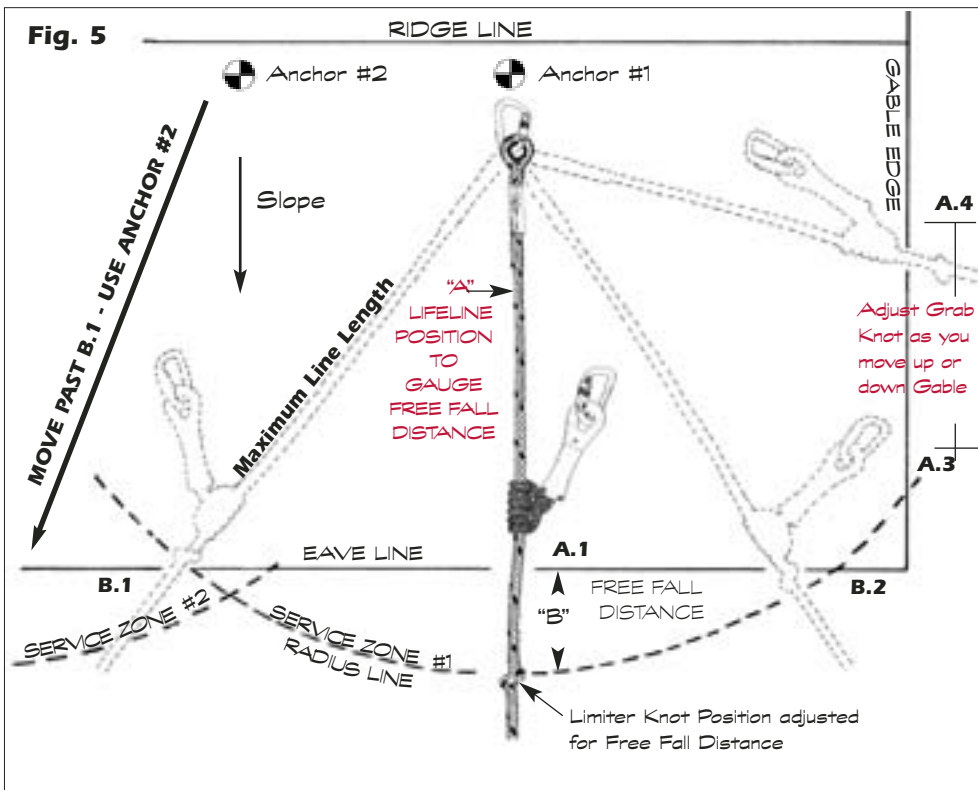

### SERVICE ZONE:

The radius of a service zone, that is, the area of protection provided by a single anchor point based on a free fall distance, is proportional to the rafter length. The longer the rafter, the greater the service zone radius. It is recommended that you position anchors so that service zones overlap.

### SETTING UP THE LIFELINE:

- 1) Attach lifeline to anchor point and connect rope grab to your shock absorber using a carabiner.
- 2) Position the lifeline as shown in Fig. 5, parallel to the slope of the rafter. **Position "A"**
- 3) Walk to the eave line while sliding the grab knot down the lifeline.
- 4) At position "A.1" determine the "FREE FALL DISTANCE" and fix the limiter knot position.

**NOTE: TERMINATION KNOTS HAVE BEEN DELETED FROM FIG. 5. ALWAYS MAKE SURE YOU HAVE A TERMINATION KNOT 12" FROM THE END OF YOUR LIFELINE.**

### LIMITER KNOT USED AS A FREE FALL GAUGE DEVICE:

5) When calibrated, the limiter knot position on the lifeline can be used as a gauging or warning device. By fixing the limiter knot position based on the free fall distance "B" and the Anchor Point #1 above, an "Service Zone #1" is created. See Fig. 5. The service zone defines or limits the free fall exposure to a plunge fall (straight down when standing at point A.1) or by a swing fall (from points B.1 / B.2), or along a gable edge. Illustrated in Fig. 5, by a dotted radius line, the service zone limit is reached when the limiter knot intersects the eave or gable edge at points B.1 / B.2 or between points A.3 and A.4.

When the service zone limit is reached, the limiter knot will prevent any further travel along the eave or gable end. However, travel upslope would be permitted. In order to carry on work outside the service zone created by Anchor Point #1 and still maintain the free fall distance determined by the user's fall protection plan, a second anchor point with an overlapping zone must be used.

**Example:** Service Zone #2 shown in Fig. 5.

### TO DETERMINE LIMITER KNOT POSITION:

6) **Two of the factors required are:** The distance between the work surface where you are standing and the connector point on the body harness (usually about 4 ft if you are standing), and the remainder when that distance is subtracted from 6 ft, (usually about 2 ft), or the maximum free fall distance permitted by your work plan. If you are sitting or crouched when working, the free fall distance may be increased. This means that for most applications when working near the eave or gable edge, the limiter knot would be positioned on the lifeline about two feet past the eave line from point A.1 when the lifeline is in Position "A", as shown in Fig. 5.

To determine the exact free fall distance, you would need to calculate how far you would fall from point A.1 before your equipment would begin to arrest the fall, then deduct that amount from 6 ft.

### ADDITIONAL INFORMATION:

**Where to locate anchors**  
**Planning the length of fall Component compatibility**

- See **SUPER ANCHOR** ARS 2x8 Anchor Manual, Rev. 3/2000.
- See **FALL ARRESTOR** Body Harness Manual, Rev. 2000.
- See **SUPER ANCHOR** Compatibility Charts, Rev. 3/2001.

Deceleration of the grab knot, shock absorber deployment, harness stretch, or other factors that in themselves do not create additional "free fall", are not calculated as free fall distance, but are added to the overall length of a fall.

### GABLE EDGE ADJUSTMENT:

7) A worker at point A.3 can continue to work upslope provided the free fall distance does not increase. However caution is needed. If a fall occurs between points A.3 and A.4, the lifeline could jump over the eave/gable corner just below A.3, resulting in a free fall distance of more than 6 ft. It is suggested that you move the rope grab up the lifeline as far as possible and still perform your work as you travel along the gable edge. Several adjustments may be needed.

### WARNINGS / HAZARD EXPOSURES:

- 8.0 In the event of a free fall, do not grab hold of the Super Grab rope portion attached to the lifeline. This may interfere with the grabbing ability of the knot. If the limiter knot has been fixed in the correct position it will act as a failsafe.
- 8.1 Be aware of any obstacles that might occur below the eave line if you should fall.
- 8.2 Guard against any abrasion hazards at the ridge, the eave and especially at the gable edge. Sheet metal or sharp wood edges may cut the lifeline.
- 8.3 Do not allow the lifeline to become wrapped or entangled around objects above or off to your side.
- 8.4 Do not wrap the lifeline around any body parts.

### CALCULATING THE LENGTH OF A FALL:

How far will you fall before your safety equipment stops you? There are several factors to consider:

- 1) The distance between the work surface and the D-ring or harness connection
- 2) Slack in the harness fabric
- 3) The length of the lanyard or shock absorber component, and shock absorber rip out (deployment)
- 4) The distance the rope grab will travel down the lifeline, as well as any anchor deflection
- 5) When exposed to a maximum free fall of 6 ft, this "Length of Fall" can range between 11 ft. and 15 ft.

**LIFELINE AGING AND REMOVAL FROM SERVICE:**

How long can a lifeline remain in service and still comply with safety standards? The manufacturers of synthetic rope and webbing do not make recommendations as to how long fabrics will last. Environmental conditions such as ultra violet rays and prolonged exposure to the elements, storage and maintenance of equipment, all vary considerably from one user to the next.

If you are using our equipment for outside construction in roofing or framing, you can expect that a lifeline will become damaged within several months, and will not pass the inspections required in this manual. If the lifeline is over 2 years old, we recommend that you remove it from service as a good safety practice. There is no sure way to know if the fibers have deteriorated without doing destructive testing.

**INDIVIDUAL COMPONENT DAMAGE:**

If it is known or determined by inspection that the lifeline, Super Grab, or other components have not been subjected to a fall impact or other extreme force, then individual components that no longer function properly, show signs of wear, or have been damaged from abuse, may be replaced with the same or compatible components.

**DISPOSAL:**

Due to a fall Impact: a.k.a. "In service loading". The complete fall protection system must be removed from service if subjected to a fall impact. This includes the lifeline, Super Grab, carabiners or snaphooks, harness, shock absorbers, lanyards, and anchorage devices.

**Voluntary Removal: - "Due to aging of components"**

Dispose of all components and do not mix new replacement parts with old ones.

**METHOD OF DISPOSAL:**

Care must be taken to dispose of equipment in a way that prevents someone from reclaiming it and using it again. Ropes should be cut up, and other components disabled in such a way as to prevent their use, and then disposed of.

**DO NOT BURN SYNTHETIC MATERIALS. TOXIC FUMES MAY RESULT.**

**NOTE REGARDING REPLACEMENT PARTS:**

A LIFELINE AS AN INDIVIDUAL COMPONENT, ALWAYS COMES FURNISHED WITH THE SUPER GRAB ATTACHED AT THE FACTORY, UNLESS ORDERED AS A CUSTOM LENGTH LIFELINE.

**INDIVIDUAL 30 FT. OR 50 FT. LIFELINES WITHOUT THE SUPER GRAB ARE NOT AVAILABLE.**

**QUALIFIED PERSON:**

One who by possession of a recognized degree, certificate, or professional standing, or by extensive knowledge, training and experience, has successfully demonstrated the ability to solve or resolve problems relating to the subject matter, the work, or the project. (See ANSI A10.14.91)

**COMPETENT PERSON:**

One who is capable of identifying existing and predictable hazards in the surrounding or working conditions that are unsanitary, hazardous or dangerous to employees, and who has the authority to take prompt corrective measures to eliminate such hazards. (See ANSI A10.14.91)

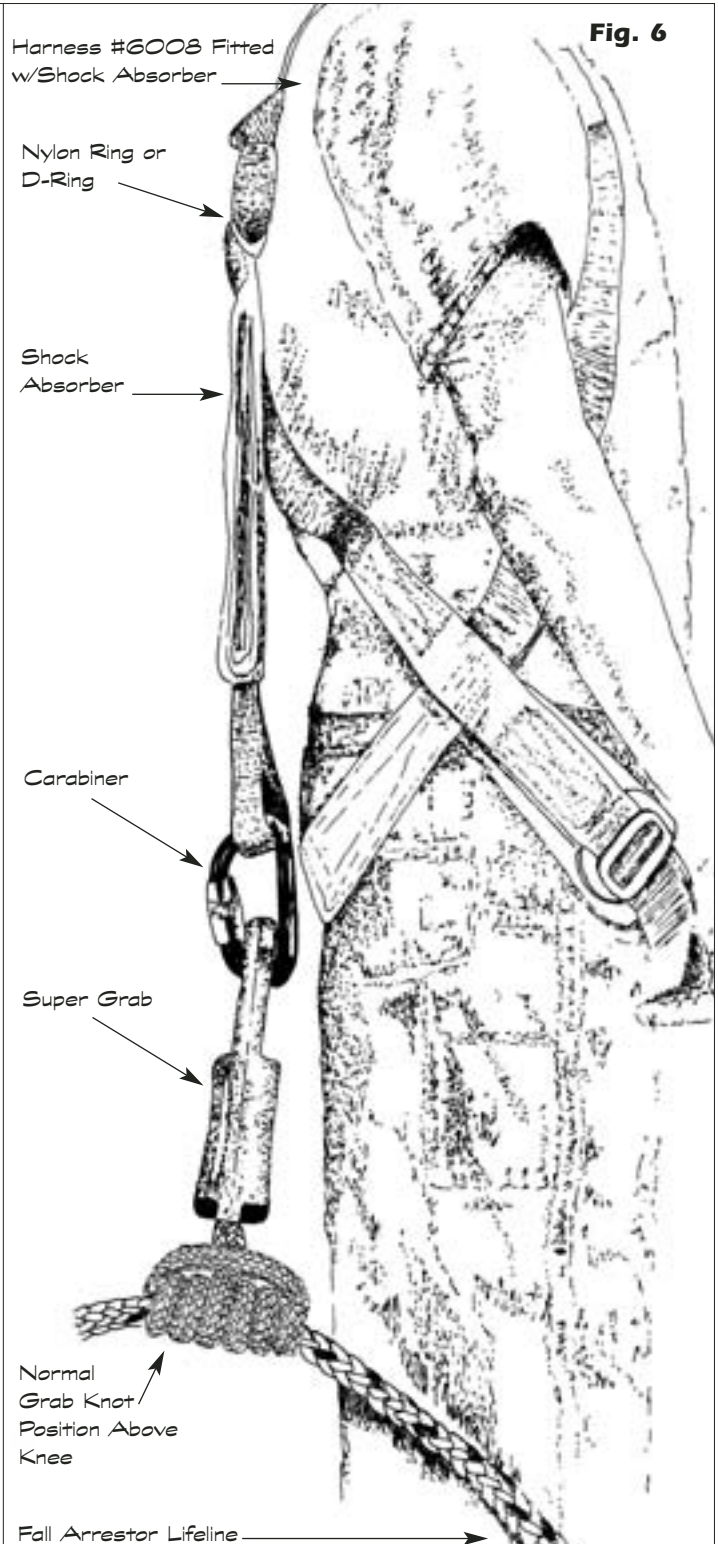

**Fig. 6**

**CERTIFICATION STATEMENT OF COMPLIANCE: TRIPLE SLIDING HITCH / PRUSSIC KNOT**

OSHA Non-Mandatory Appendix "C" to Sub-Part M, Section H-(8) indicates that knots should not be used for lifeline connections because knots can reduce rope strength by as much as 70%.

The Super Grab complies with certification tests of both OSHA and ANSI A.10.14.91. (EXEMPT FROM Z359 BI-DIRECTIONAL TYPE III) and no failures have been reported by our users since we first offered this device in 1992. In addition, Compliance Letters have been issued by the following agencies:

- U.S. Dept.. of Labor dated 1993 and 1995,
- WISHA WAC 296-155 dated 1993, and
- CAL-OSHA CSO-1670 (m) dated 1999

# Compatibility Chart / D-Ring Harnesses



#6001 shown with accessory shock absorber #6025 connected to D-Ring.

Harness Models w/Back D-Ring Configuration

- #6001
- #6011
- #6035
- #6036
- #6037
- #6038



Backside D-Ring Shown

**Carabiners**  
Factory supplied component is Part #5006 Aluminum Auto-lock

Integral Shock Absorber w/Snaphook #6025



Integral Shock Absorber w/Carabiner #6026



Web Lanyard w/Snaphook  
18' #6002  
24' #6006  
48' #6021  
60' #6023  
72' #6014



Web Lanyard w/Carabiner  
18' #6009  
24' #6012  
48' #6022  
60' #6024  
72' #6017



Shock Absorber w/Snaphook & Small D-Ring #6018



72" Shock Absorber w/Snaphook #6027



72" Shock Absorber w/Carabiner #6028



A Web Lanyard is attached to the shock absorber using a carabiner only.

The Lanyard is then attached to the rope grab knot using a carabiner only.

**WARNING:**  
Do not connect a snap hook or rebar hook to a plastic eye thimble or to a Super Grab rope grab device.

All connections shown here may be used and are component compatible with equipment mfg. or supplied by **SUPER ANCHOR SAFETY**

**WARNING:**  
FRONT D-RING CONNECTIONS ARE NOT APPROVED FOR FALL ARREST APPLICATIONS. USE FRONT D-RING CONNECTIONS FOR WORK POSITIONING ONLY!!!

"FALL ARRESTOR" Super Grab w/Carabiner Part #4015



"Fall Arrestor" Lifeline

# Compatibility Chart / Nylon Ring Harnesses

Harness Model #6008  
w/shock absorber



Web Lanyard  
connected to  
nylon ring  
w/carabiner

**NOTE:** This configuration is used when the "length of fall" does not permit the use of a shock absorber which adds approx. 42" to the length of fall. When the web lanyard is not used it must be removed from the harness.

Integral  
Shock  
Absorber  
w/Carabiner  
#6026



Integral  
Shock  
Absorber  
w/Carabiner  
#6026



Web Lanyard  
w/Carabiner  
18" #6009  
24" #6012  
48" #6022  
60" #6024  
72" #6017



Custom  
Web Lanyard  
#6034/#6033



72" Shock  
Absorber  
w/Carabiner  
#6028



**WARNING:**  
DO NOT  
ATTACH  
SNAPHOOK OR  
REBAR HOOK  
TO NYLON RING

**WARNING:**  
Do not connect a snap hook or rebar hook to a plastic eye thimble or to a Super Grab rope grab device.

Accessory  
web lanyard  
attached to  
absorber  
w/carabiner

**Carabiners**  
Factory supplied  
component is  
Part #5006  
Aluminum Auto-lock

"FALL  
ARRESTOR"  
Super Grab  
w/Carabiner  
Part #4015



"Fall Arrestor" Lifeline

All connections shown here may be used and are component compatible with equipment mfg. or supplied by **SUPER ANCHOR SAFETY**

# Compatibility Chart / Anchorage Connections

Anchorage devices mfg. or distributed by Super Anchor Safety are component compatible with all "Fall Arrestor" safety equipment also mfg. and distributed by Super Anchor Safety, provided the specific instruction manuals for each type of equipment being used, are strictly followed, and that OSHA regulations are complied with.

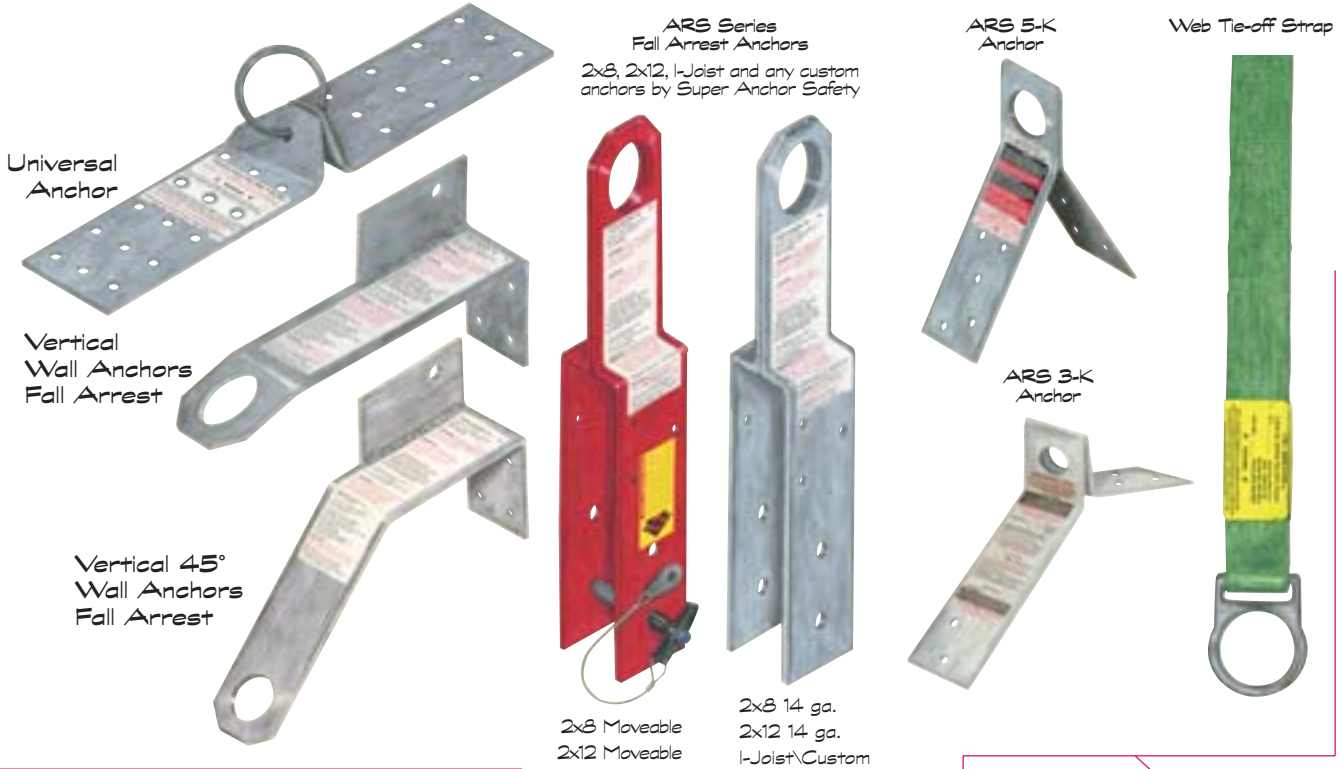

Universal Anchor

ARS Series Fall Arrest Anchors  
2x8, 2x12, I-Joist and any custom anchors by Super Anchor Safety

ARS 5-K Anchor

Web Tie-off Strap

Vertical Wall Anchors Fall Arrest

Vertical 45° Wall Anchors Fall Arrest



2x8 Moveable  
2x12 Moveable



2x8 14 ga.  
2x12 14 ga.  
I-Joist/Custom  
2x8 11 ga.  
2x12 11 ga.



ARS 3-K Anchor



Approved connector to anchor point locking type carabiner  
#5001 - Auto-lock Steel  
#5006 - Auto-lock Aluminum



Lifeline Use locking carabiner

Lifeline w/locking snap hook

Approved connector to anchor point locking snap hook #5005



## Alternative Attachment

Connect Web Lanyard w/locking carabiner to anchor



## Alternative Attachment

Connect Web Lanyard w/locking snaphook to anchor



**WARNING:**  
Installation of anchors and the use of those anchors with fall protection equipment must comply with the instructions provided for each type of component being used. If you need instruction manuals, please request them at no charge.

**WARNING:**  
**Non-Compatible Connections**  
Do not connect lifeline directly to anchors by tying. Do not connect a Super Grab rope grab device to the anchor point. Do not tie web lanyards to anchors.



# Non-Compatibility Chart / Locking Snaphook



**WARNING:**  
Do not make any of the connections shown here.

Locking Snap Hook or Rebar Hook non-compatible connections shown below.

Across Lifeline  
or Directly to a Web Lanyard

Loop end of Shock Absorber

Rebar Hook on Lanyard

Lifeline Thimble

Lanyard w/Carabiner

Loop end of Tie-off Strap

Loop end of Web Lanyard

Snaphook

Nylon ring of harness

Super Grab eye thimble



# Non-Compatibility Chart / Locking Carabiner



**WARNING:**  
Do not make any of the connections shown here.

Locking Carabiner non-compatible connections shown below.

Shock Absorber w/Snap Hook

Loop end of Tie-off Strap

Rebar Hook on Lanyard

Snap Hook

Carabiner

Across Lifeline

or Across a Web Lanyard

# SUPER ANCHOR®

## Instruction/Specification Manual:

Stainless Steel Fall Arrest Anchors  
ARS 2x8, ARS 2x12, I-Joist, Moveable ARS,  
Vertical Wall Anchor, and Custom Anchor

**NOTICE TO USER: You must read, understand, and receive training from this manual before installing or using SUPER ANCHOR Fall Arrest Anchors.**

### SPECIFICATION OF USE:

Super Anchors are designed for use as a fall protection anchorage device to be used by one person at a time. They may be installed onto the top chords of trusses, rafters, I-joists, and beams as a temporary anchorage device, or can be flashed into the roofing membrane and left in place as a permanent fixture. In addition, they are easily installed during construction, or may be retrofitted to existing structures. Super Anchors are designed to fit standard wood framing. Custom size anchors for wood framing or structural steel are available upon request.

### PRODUCT SPECIFICATION MANUAL:

The singular use of the word "manufacturer" and "factory" in this manual refer to "American Roof, Inc." / DBA SUPER ANCHOR SAFETY and no others. This document represents the primary form of the Instruction/Specification manual for Super Anchors and must be referred to when cited by supplemental instructions. Do not use instructions provided by other equipment manufacturers for any equipment manufactured or supplied by SUPER ANCHOR SAFETY. Verbal instructions outside the specification of this manual are considered unauthorized. Supplemental instructions or specifications must be provided in written form from the manufacturer.

### COMPONENT COMPATIBILITY:

Fall protection equipment supplied by more than one manufacturer, including anchors, may not be interchangeable and may create unforeseen hazards. It is recommended you use the "Fall Arrestor®" or "Total Package®" personal fall protection equipment manufactured by SUPER ANCHOR SAFETY, when Super Anchors are specified for use. When mixed manufacturer components are used, they should be ensured for compatibility by a "Competent Person". 1926:502 Appendix C (II)(c). Any recommendation regarding the use of Super Anchors in this or other equipment manuals published by SUPER ANCHOR SAFETY, is based on the exclusive use of our equipment as part of a complete fall protection system, and in no way specifies or recommends the products of other equipment manufacturers. Request Component Compatibility Chart.

### FOREIGN LANGUAGE TRANSLATION:

It is the sole responsibility of the user to provide foreign language translation from a certified translation service if this manual is not available in the user's native tongue.

### DISCLAIMER:

The strength rating of the anchor itself in no way makes recommendation or endorsement of the framing to which the anchor is attached. It is the responsibility of the user or specifier to determine if the structure is capable of supporting the intended fall protection system being used, including the anchor. Furthermore, if the "User" (see def. pg. 30), modifies the anchor in any way, or uses it for purposes other than personal fall protection, the manufacturer will not accept responsibility for any failure that may arise from such misuse.

### MODIFICATION OF USE:

Modification of use or dimension in the Super Anchor, must be validated by the manufacturers written instructions. Explanations of the instructions contained in this manual should be directed to the manufacturer.

Complies with Fed-OSHA 1926:502 (d)(15)

US PATENT NO. 5,370,202

Fig. 1



Fig. 2

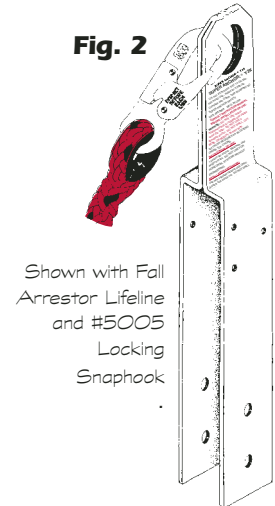

### ARS 2X8

### ARS 2X12

RAFTER SIZE			RAFTER SIZE		
2X4	2X6	2X8	2X10	2X12	
Part#	Gauge		Part#	Gauge	
1001	14 ga.SST		1002	14 ga.SST	
2805	11 ga.SST		2806	11 ga.SST	
<b>Above anchors use replacement fastener kit, Part# 2006.</b>					
Moveable ARS Anchor			Moveable ARS Anchor		
1014*	11 ga.SST		1015*	11 ga.SST	
<b>* Moveable ARS anchors are SST powder coated red.</b>					

### OSHA Guidelines:

OSHA standards allow a maximum free fall distance of 6 Ft., arresting forces of 1800 lbs. or less, and arrest of a free fall before striking an object or lower level below. 1926:502 (d) (16) (ii-iii-iv). In order to comply with OSHA or other safety standards, it is recommended that you draft a "Length of Fall Plan" as part of a **Job Specific Plan, "JSP"** for each employee. This should include shock absorber extension, rope grab deceleration, harness stretch, connector point of the body harness relative to the work surface, anchor deflection, and other factors as well as the distance between the ground or lower level and the leading edge. Consult page 11 for a sample "Length of Fall Plan".

### STRENGTH USE AND RATING:

Super Anchors fabricated from 14 Ga. SST are structurally tested to withstand an average force of 7,000 lbs. when applied perpendicular or parallel to the attachment point. **Testing certification does not represent the structure to which the anchor may be attached.**

## SPECIAL APPLICATIONS:

### HORIZONTAL LINE USE:

Super Anchors may not be used for horizontal line anchorage points unless specifically engineered by a "qualified person". Refer to OSHA regulations, ANSI A.10.14.91, and ANSI Z-359 definitions of horizontal line and "Qualified person".

### MULTIPLE USERS:

Under the supervision and engineering of a "qualified person," two workers may attach to a single Super Anchor when the slope is 3/12 or less, and the workers are rigged so as not to be exposed to a free fall hazard of any type. **In addition:** Each worker must be equipped with all of the components of the "Total Package System" manufactured by Super Anchor Safety. Connect lifeline to anchor with carabiner only, no snaphooks: and do not perform work when snow or ice are present on the work surface.

## DIMENSION SPECIFICATIONS

Standard size anchors are supplied in 14 or 11 gauge, #304 stainless steel, are 2" wide, and have 6-1/2" stem heights. ARS 2x8 and ARS 2x12 permanent and moveable types have an inside dimension of 1-5/8".

### ATTACHMENT HOLE:

A 1-1/8" hole is provided at the stem top and will accept a locking type snaphook or carabiner supplied or specified by SUPER ANCHOR SAFETY. User must ensure compatibility with other types of connectors.

**WARNING:** Never connect a lifeline or lanyard by tying a knot to the attachment hole or anchor stem. In the event of a fall, the line may be severed.

### STEM SPOT WELDS:

The stem section is joined with two non-structural spot welds and one structural weld at the stem top. If the anchor legs are pulled apart or modification of the anchor is attempted, the spot welds are designed to break. If this occurs, **DO NOT USE THE ANCHOR.**

**NOTE:** The structural integrity of the anchor during use does not depend on the welds. The attachment bolt and connecting hardware provide encapsulation of the rafter.

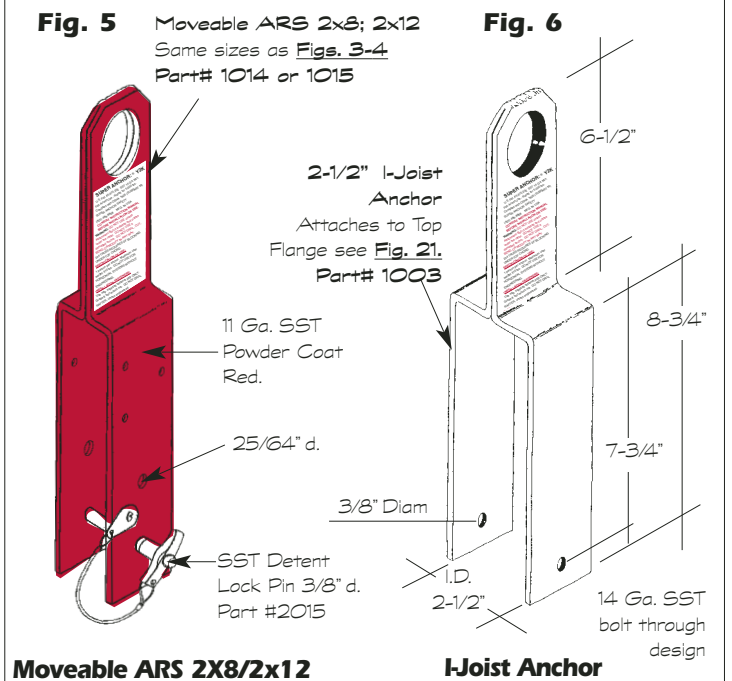
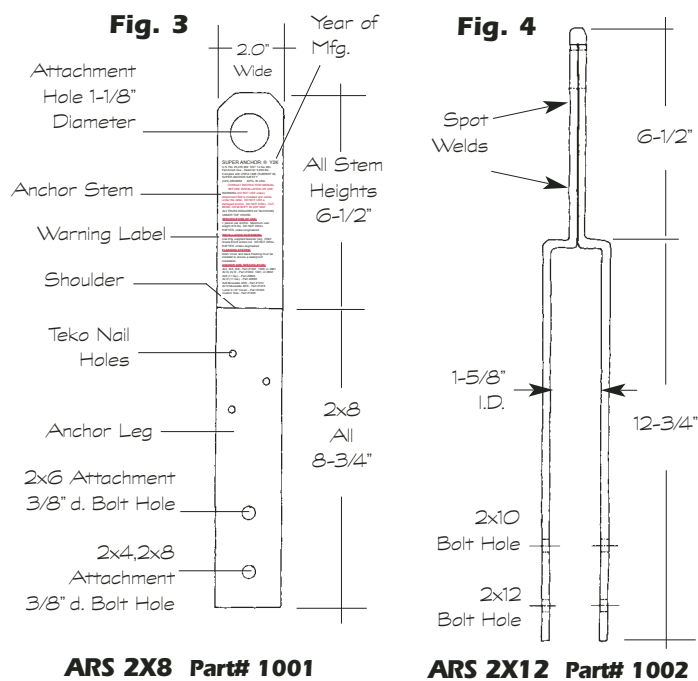

### INSPECTION OF ANCHOR BEFORE EVERY USE:

- 1) **Exterior Inspection:** The anchor stem should be perpendicular to the rafter run. (see Fig. 9), and at right angles to the roofing or sheathing indicated by the dotted lines in Fig. 8. **DO NOT USE ANY ANCHOR THAT IS BENT OR DEFORMED.** Examples of typical damage are shown in Fig. 7 & 8.
- 2) From the inside, inspect the anchor location by viewing the underside of the framing. The anchor legs should be at right angles to the rafter as shown in Fig. 9. If the anchor has shifted position, as indicated by the dotted lines in Fig. 9, the anchor may have been subjected to damage or a fall impact. Verify by exterior inspection.
- 3) There should be no space between the inside of the anchor legs and the framing. 3 Teko nails should be visible on each anchor leg side with heads flush against the anchor. The attachment bolt should be visible under the rafter bottom with the lock nut flush against the anchor leg. When installed correctly, a gap of approx. 1/2" will be visible between the bolt and rafter bottom. See Fig. 11.

### IN-SERVICE LOADING OR DAMAGED ANCHOR:

When subjected to a fall impact, in-service loading, or other damage, the anchor stem will deform as shown in Fig. 7 & 8, or the anchor may shift position on the framing member as indicated by the dotted lines in Fig. 9. Any deformation requires the anchor to be removed from service, and replaced with a new one; including fasteners. Inspect the flashing system for damage and replace if needed.

### FRAMING INSPECTION:

Do not install a new anchor in the old anchor location until the framing has been inspected for possible damage. Do not install a Super Anchor onto any defective framing members.

**WARNING:** The anchor point is only as strong as the framing itself. Correct defective installation before use.

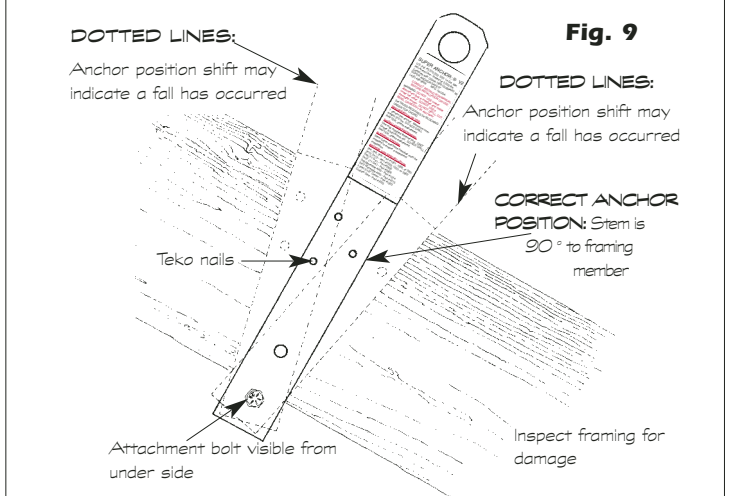
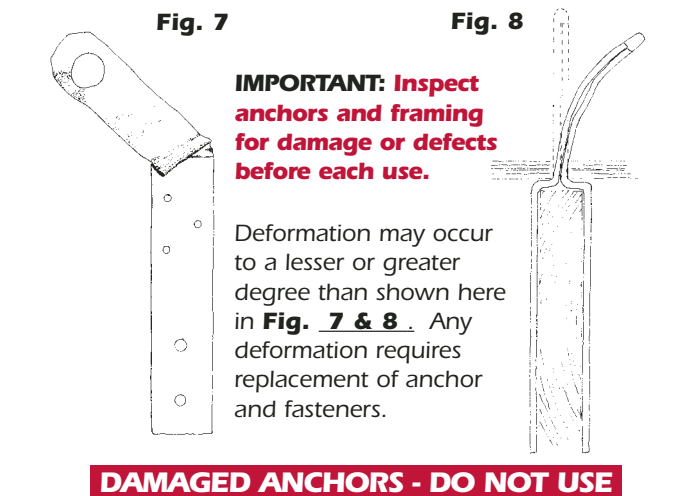

**DAMAGED ANCHORS - DO NOT USE**

## FRAMING BRACING:

Super Anchors may be installed when setting trusses or rafters, but must not be used for anchor points until the structure is capable of supporting the intended fall protection load. It is recommended that you consult the truss mfg., architect, engineer, or qualified person to determine what structural bracing or sheathing is required before using the anchors for fall protection.

### ANCHOR SHOWN ON TRUSS WITH BLOCKING

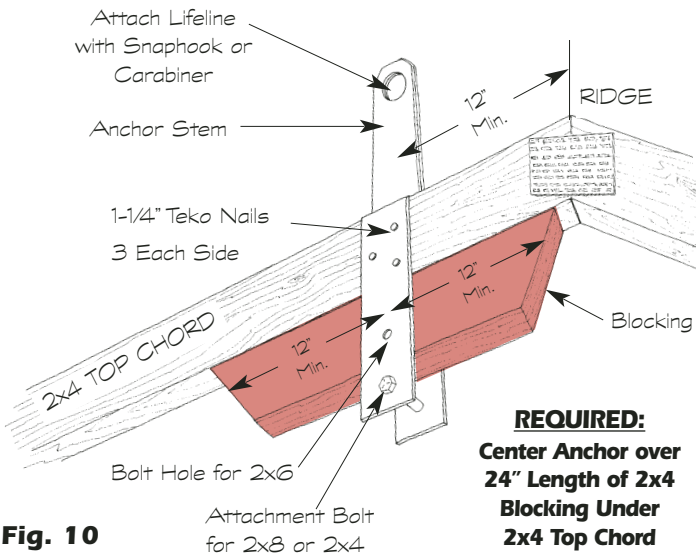

Fig. 10

### INSTALLING ARS 2x8 OR 2x12 OVER RAFTERS / TRUSSES:

- 1) Install anchor onto the top chord of a truss or rafter, a minimum of 12" down from the ridge, with the stem facing up. Do not mount over the top of sheathing because attachment bolt holes may not clear the bottom of the rafter. See **Fig. 10**.
- 2) 2x4 trusses and rafters require a 24" length of 2x4 blocking secured to the underside of the top chord. For easy attachment, cut the ends back at an angle and toe-nail both ends or sides. The anchor must be centered over the blocking as shown in **Fig. 10**.
- 3) Except for Wall or I-Joist Anchors, do not drill or bolt through the rafter and do not attach the anchor to any damaged framing, cantilevered framing, bottom chords, blocking, spliced members, damaged or drilled framing, or framing that is not part of the roof, or supporting structure, unless engineering is provided.

### ATTACHMENT BOLT / TEKONAILS:

- 5) Use only Super Anchor factory supplied fasteners for all anchor types. If fasteners are missing, do not substitute with other types. Request replacement fasteners only.
- 6) Attachment bolt must be installed under the 2x4 blocking as shown in **Fig. 10**, or under the top chord of 2x6, 2x8, 2x10, or 2x12 rafters, as shown in **Fig. 11**, with locking nut tightened securely. **DO NOT USE THE ANCHOR IF THE ATTACHMENT BOLT IS NOT INSTALLED!!!**
- 7) 1-1/2" width (2x) framing members require that 6 each 1-1/4" factory supplied teko nails are used to stabilize the anchor as shown in **Fig. 10 & 11**. This will prevent the anchor from walking down the top chord when sheathing is not in place. Short duplex nails can be substituted for moveable or temporary anchor locations. Take care to prevent nails from contacting the opposing inside anchor leg.

### MODIFICATION OF THE ANCHOR / NON-SPECIFIED USES:

- 8) Do not cut, bend, drill, or modify the anchor in any way.
- 9) Do not install anchor inverted with stem facing down, unless the framing has been specifically engineered to support the intended load.
- 10) Do not attempt to repair a damaged anchor.
- 11) Do not use anchors for hoisting, securing materials, scaffolding, or any other use that is not specifically intended for personal fall protection.
- 12) Do not use for suspended loads, such as a boatswain's chair.
- 13) Do not use as a live animal tether for camels, elephants, water buffalo, or rhinos.

### OVERHEAD USE: ELEVATOR SHAFT / SUSPENDED LOADS:

Because the anchor stem is designed to deform or bend when subjected to live loading, it should not be used for suspended loads with the stem facing up as shown in **Fig. 10**. However, when the supporting structure to which the anchor is attached is engineered to withstand the intended load, the anchor may be installed with the stem facing down and used for suspended load of a single user; such as would be required for work inside an elevator shaft.

### SHEATHING: Plywood / OSB / Other

DO NOT INSTALL ANCHOR OVER THE TOP OF SHEATHING

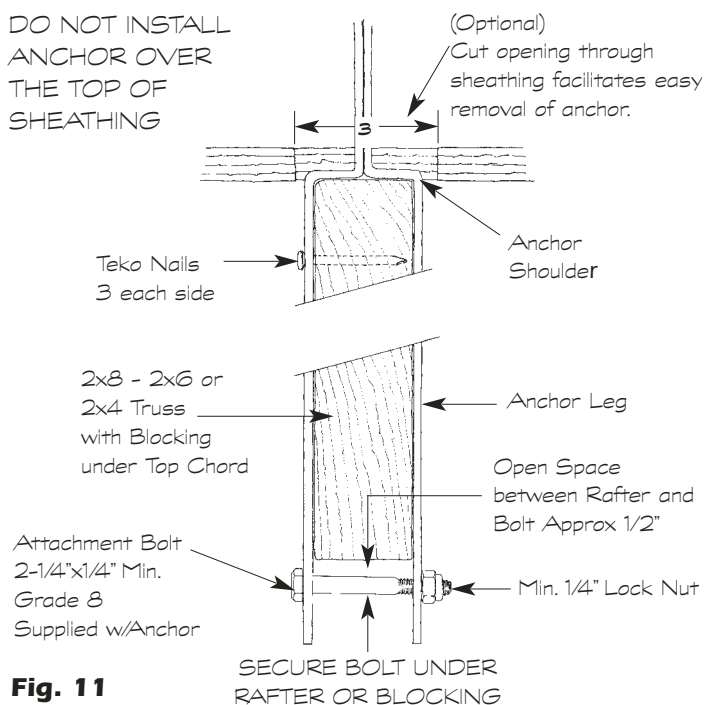
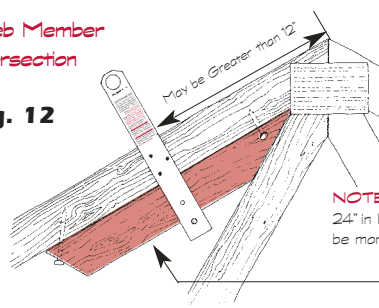

Fig. 11

Web Member Intersection

Fig. 12



**BLOCKING SUGGESTIONS  
2X4 TRUSS / RAFTERS ONLY**  
For typical truss configurations

**NOTE:** Blocking under top chord must always be a Min. of 24" in length. The anchor stem distance from the ridge may be more than 12". See **Fig. 10** for proper blocking.

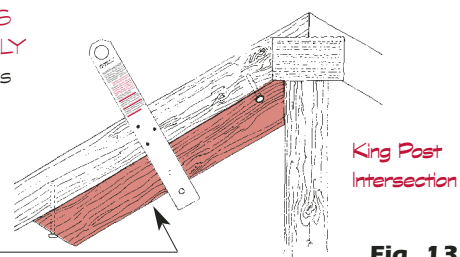

Fig. 13

# ROOF ANCHOR LOCATIONS / PLANNING PHASE

## SUGGESTED METHOD:

TRUSS BUILT ROOF STRUCTURE SHOWN.

Fig. 14

	Service Zone
	Free Fall or Ridge Line
	Anchor Location
	Free Fall Zone
	Zone Overlaps
	Adjustment Zone

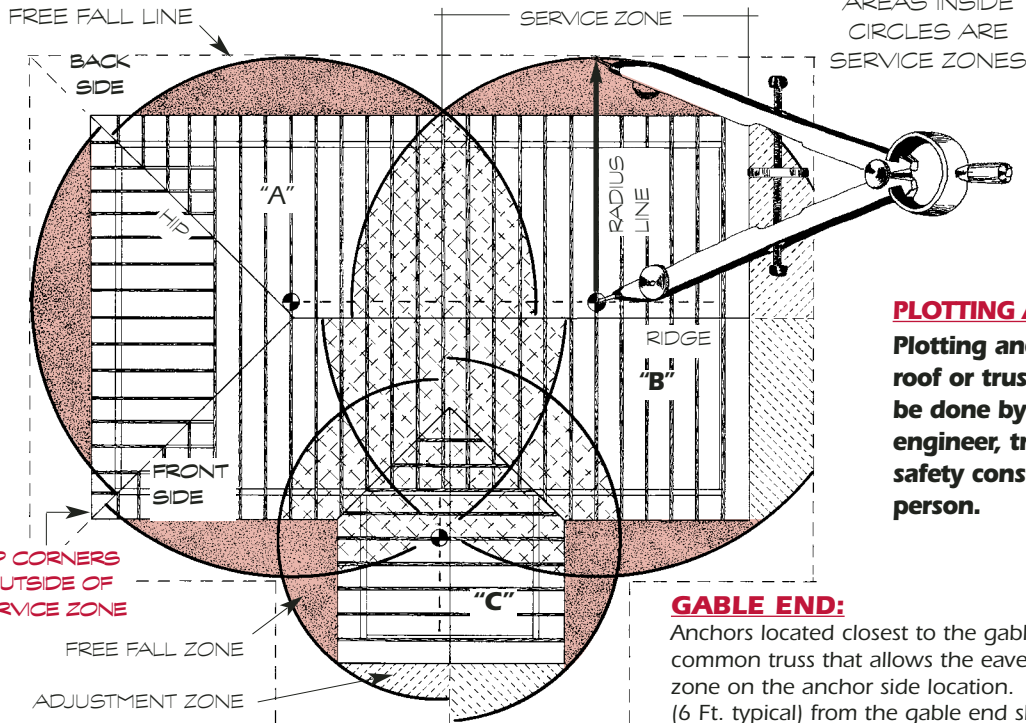

### PLOTTING ANCHOR LOCATIONS:

Plotting anchor locations on a roof or truss framing plan should be done by an architect, engineer, truss manufacturer, safety consultant, or competent person.

### GABLE END:

Anchors located closest to the gable end may be installed on a common truss that allows the eave corner to fall inside the service zone on the anchor side location. The minimum distance, (6 Ft. typical) from the gable end should be specified by the person responsible for the fall protection plan.

### JOB SPECIFIC PLAN:

Service zones plotted on a roof or truss framing plan should not be used as a specific "Fall Protection plan" unless originally designed for that reason. Variables in job site conditions, the type of equipment used for fall protection, the free fall distance, and other factors that are not usually known in the framing/planning phase, need to be addressed in a written Job Specific Plan, "JSP", by each employer. Additional permanent or temporary anchors may be needed in order to provide adequate fall protection.

### AREAS OUTSIDE OF SERVICE ZONES:

Due to the geometry of hip framing, the outside hip corners may not fall inside the service zone. Protection can be provided by additional permanent or temporary anchors and could be addressed in the "JSP" as "limited duration exposure". Confirm with your safety official.

### FREE FALL LINE:

OSHA specifies a maximum free fall distance of 6 Ft. The actual distance for each job will vary according to several factors and should be specified in the JSP. When plotting anchor locations on a roof or truss framing plan and the actual free fall distance is not known, it is recommended that you use the slope factored equivalent of 3 ft. **Example: 12/12 slope, mark free fall line on the plans at 2 Ft. This should allow sufficient service zone overlap to provide adequate anchorage points.**

### QUANTITY AND SPACING OF ANCHORS:

Anchors are usually installed on the back side of the roof a minimum of 12" down from the ridge, but may be located anywhere provided the framing will support the intended load. Anchors should be spaced so as to allow sufficient zone overlap at the leading edge or gutter line, and should be plotted using the shorter back side radius line.

### FLASHING SYSTEM: - - -

Fig. 15

Unless otherwise specified by the purchaser, 14 gauge ARS 2x8;2x12 anchors come with the flashing system shown in Fig. 15. When ordering I-Joist, Custom anchors, or 11 gauge ARS 2x8;2x12, flashings are specified and ordered as accessory items from the list below. Custom flashing sizes and materials are available upon request.

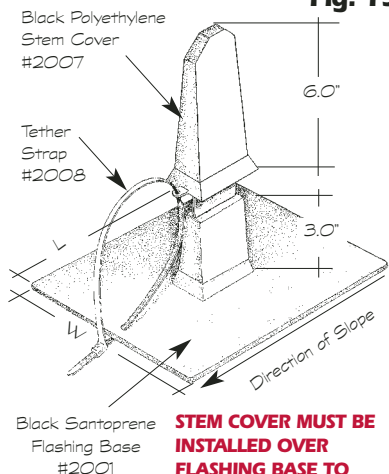

**STEM COVER MUST BE INSTALLED OVER FLASHING BASE TO ENSURE A WATERPROOF SYSTEM.**

Flashing Type	Part Number	Typical Use	Color	Dimension		
				L	W	H
Santoprene	2001	Shake/Composition	Black	10.0"	8.0"	3.0"
Lead 2.5 lb.	2003	BUR/Single Ply	Gray	16.0"	16.0"	3.0"
EPDM w/Alum. Edge	2018	Metal	Gray	8.0"	8.0"	3.0"
EPDM w/Flex Alum Base	2020	Tile	Gray	20.0"	20.0"	3.0"
Black Stem Cover	2007	All Flashings	Black			6.0"
Gray Stem Cover	2007G	All Flashings	Gray			6.0"
Terra Cotta Stem Cover	2007T	All Flashings	Brick			6.0"
Tether Strap	2008	All Stem Covers	Black	15.0"		

**Flashing Service Life:** EPDM approx. 20 years. Santoprene approx. 15 years.

**Caulking/sealants: RECOMMENDED BUTYL CAULKINGS ON ALL FLASHINGS.**

**NON-WATER BASED PAINTS MUST NEVER COME IN CONTACT WITH EPDM OR SANTOPRENE FL.**

**WARNING:** Non-specified coatings, sealants, or caulking may have adverse chemical reactions to the flashing system, causing premature deterioration. Flashing base fasteners must not be more than 3/4" from the outside edge of the flashing.

## GUARDING AGAINST HAZARDS

This is a non-mandatory guideline. Falling through open trusses or framing, as shown in **Fig. 16**, may create unforeseen hazards. Care must be taken to guard against falls over the upper leading edge.

Potential top chord failure when forces are exerted in this direction.

**Fig. 16**

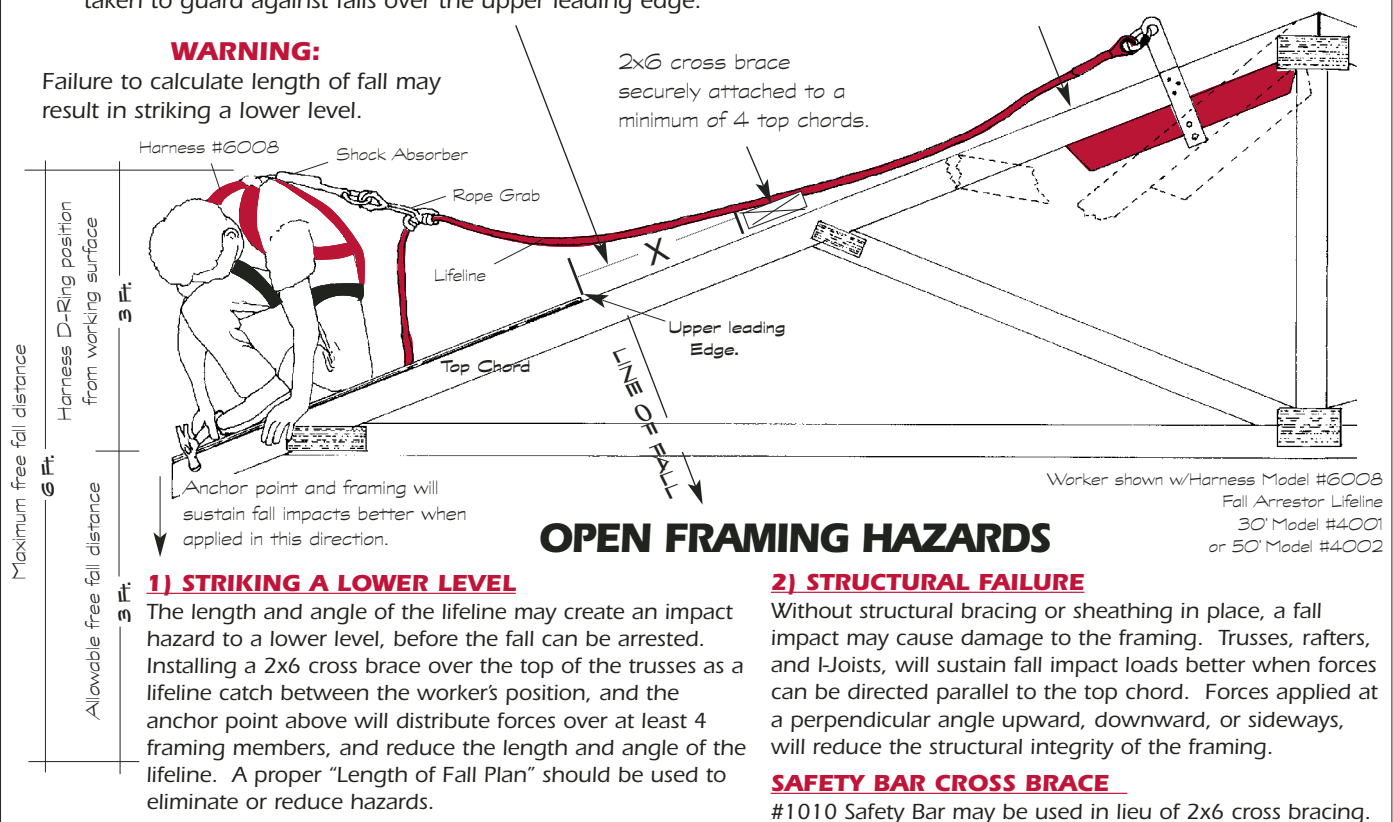

### INSTALLING A 2X6 CROSS BRACE

A cross brace positioned to catch the lifeline should span at least 4 trusses and be securely attached to prevent movement in the event of a fall. The distance between the cross brace and upper leading edge of the worker's position should be wide enough to allow the worker to fall between the two points. See (X) in **Fig. 16**.

## DEFINITIONS:

### REGARDING TERMS USED IN THIS MANUAL:

**"Manufacturer"** and **"Factory"** - American Roof, Inc. dba/SUPER ANCHOR SAFETY

**"User"** - Person who purchases, uses, employs, or trains, those using fall protection equipment.

**"Competent Person"** - One who has received instruction and is able to train and instruct others and has the authority to identify and eliminate job hazards.

**"Qualified Person"** - One who by degree, certificate, professional standing, or by extensive knowledge, training and experience, is able to provide consultation regarding fall protection.

**"Component Compatibility"** - Fall protection equipment that is tested, certified, designed, or ensured by the manufacturer or a qualified person to provide a safe working system without creating a hazard to the user.

**"Compatibility Chart"** - Color specification guide illustrates recommended methods of connecting equipment manufactured by SUPER ANCHOR SAFETY, and how to avoid potentially hazardous combinations and connections. Free upon request. (Included in Total Package Manual)

**"Double Locking Snaphook / Carabiner"** - Connecting hardware rated for fall protection use, that by design has a primary and secondary locking feature and can not disengage by unintentional motion.

**"Vertical Lifeline"** - Specified as a lifeline attached to a single anchor point for use by a one person at a time.

**"Horizontal Lifeline"** - A line that is parallel to the ridge or work surface, or perpendicular to the slope, and has two or more anchor points.

**"Job Specific Plan" ("JSP")** - A fall protection work plan which identifies all potential fall hazards specific to a particular jobsite, and specifies any and all methods of fall protection to be used; as well as all procedures to be followed in order to minimize workers exposure to fall hazards. In addition, it identifies the type, make, and model of equipment and anchorage devices that are to be used which will ensure that workers are adequately protected. This is a generic definition only. Consult with your local OSHA official for other requirements, if any.

**"Service Zone"** - An area served by a single anchor, where work is carried on and which by design (JSP) identifies, limits, or restricts free fall hazards. Represented by sample plan in **Fig. 14**.

**"Adjustment Zone"** - A part of the service zone that requires the worker to adjust the lifeline length using the rope grab device, in order to maintain the free fall distance specified in the JSP. It is typically the gable end area of the roof.

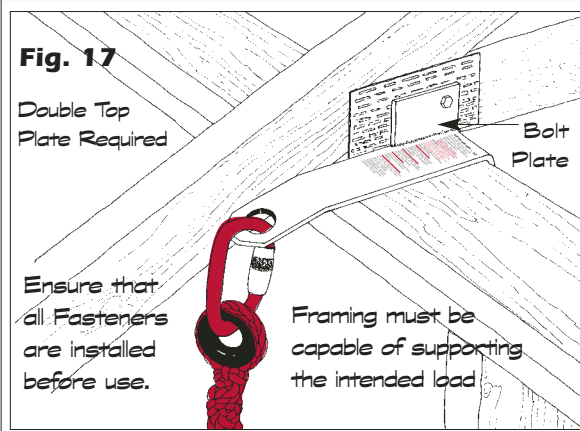

## WALL ANCHORS:

1/8" thick SST Wall Anchors come in two sizes and fit 2x4, 2x6, & 2x8 top plate. They require double top plate, attachment bolt through rafter, and 4 -16d sinkers as shown in **Fig. 18 - 20**. Drill bolt hole through rafter. Use chart to select proper anchor size. **USE ONLY FACTORY SUPPLIED FASTENERS.**

### PERMANENT INSTALLATION:

It is suggested that you notch back side of wall plates for flush mount to accept drywall. Notch bird blocking around bolt plate and stem section if needed.

### TEMPORARY INSTALLATION:

**Attachment Bolt Required.** Use 16d duplex & notch bird blocking around stem. Remove anchor from inside when finished.

## SIZE CHART

RAFTER SIZE	STD Anchor		45°
	#1004	#1004A	
WALL TOP PLATE SIZE			
2X4	2X4	2X6	2X4
	MAX Slope 7/12	2X8 All Slopes	10/12 or Greater
2X6 - 2X12	ALL SLOPES		

**BEND IN STEM MUST NOT EXCEED DIMENSION SHOWN FOR MODEL..**  
**See Figs. 19 & 20.**

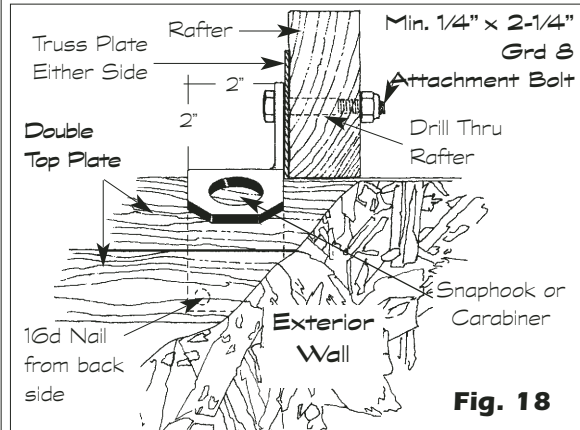

## I-JOIST / TJI / WEB TRUSS:

I-Joists with a top flange of between 1-1/4" and 2-3/4" can be fitted with either the #1003 I-Joist or #1001 ARS 2x8. Request custom anchors for wider widths. **DO NOT PULL ANCHOR LEGS APART OR MODIFY ANCHOR.**

### WEB FILLER

1) Attach OSB or Plywood filler to both sides of the I-Joist center web as shown in **Figs. 21, 22, & 23**.

Keep filler 1/2" below top flange. The combined widths of the filler and center web must not exceed the anchor legs I.D. as specified in **Fig. 22**. When the anchor I.D. is 1/4" or less in width than the top flange, it may be possible to shave up to 1/8" off each side of the flange. Consult TJI Mfg. first.

2) Anchor shoulders must be seated onto top flange with anchor legs centered over web filler as shown in **Fig. 21**. Drill through filler and center web using attachment bolt hole as a guide. **DO NOT DRILL THROUGH ANCHOR LEG MATERIAL. DO NOT INSTALL INVERTED.** Insert factory attachment bolt and secure lock nut.

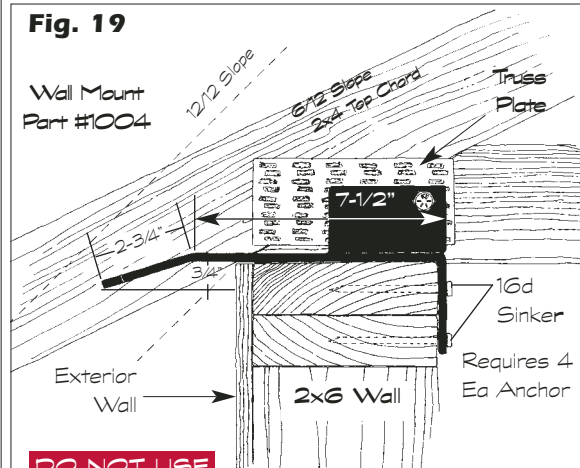
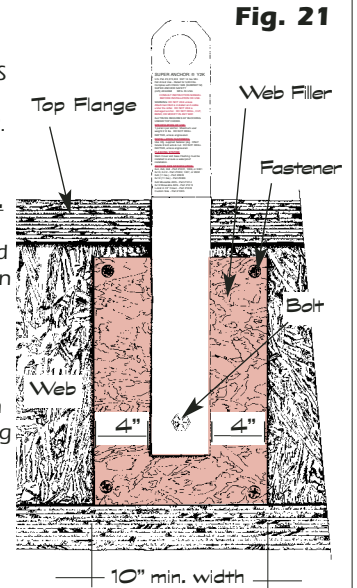

### ENGINEERING:

3) **BEFORE USE**, it is recommended that you consult the I-joist manufacturer or engineer regarding installation of Super Anchors. The specifications contained in this manual are suggested methods of installation only.

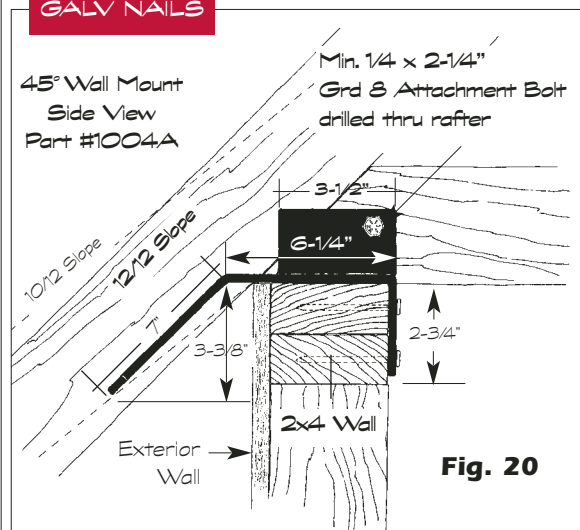

**Fig. 22**

**Part #1003**  
2-1/2" I-Joist Anchor Fits  
I-Joist Top Chords 1-3/4"  
up to 2-3/4"

Anchor I.D. 2-1/2"

Top Flange  
1/2" open space  
Web Filler  
OSB or Plywood  
Center Web  
Anchor Leg

Drill through I-Joist:  
Attachment Bolt Min.  
Grade 8 3-1/4" x 1/4"

Filler Secured  
to Center Web

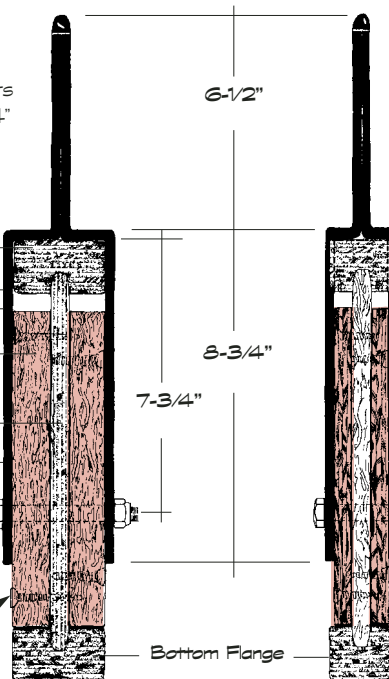

**Part #1001**  
ARS 2x8 Fits  
Top Chords  
1-1/4" up to 1-3/4"  
Anchor I.D. 1-5/8"

Top Flange  
notched to fit  
anchor I.D.

**Fig. 23**

Drill through I-Joist:  
Attachment Bolt  
Min. Grade 8  
2-1/4" x 1/4"

**NOTE: ARS**  
2x8 Anchor use  
lower bolt hole for  
I-Joist Installation.

# SUPER ANCHOR®

## ARS 5-K Re-Usable Anchor

### SURFACE MOUNTED / FALL ARREST ANCHOR INSTRUCTION / SPECIFICATION MANUAL

#### TRAINING AND INSTRUCTION REQUIREMENTS:

ANYONE WHO USES SAFETY EQUIPMENT MUST FIRST RECEIVE TRAINING AND INSTRUCTION THAT MEETS THE REQUIREMENTS OF FEDERAL OSHA 1926.503 AND COMPLIES WITH THE INFORMATION CONTAINED IN THIS MANUAL.

#### USER COMPLIANCE

The ARS 5-K is designed to be used as a single person anchorage point for "FALL ARREST" and "FALL RESTRAINT" methods of Fall Protection and meets the requirements of Fed OSHA 1926; 502(D) of Subpart M. The user must ensure component compatibility with a Full Body Harness, Shock Absorbing or Straight Lanyard, Lifeline, Rope Grab Device, and connecting hardware.

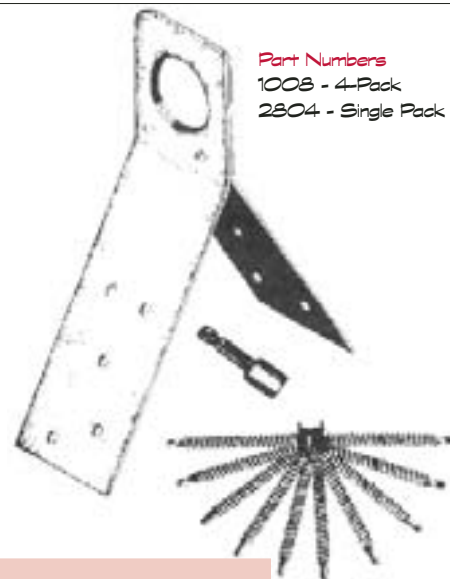

Part Numbers  
1003 - 4-Pack  
2804 - Single Pack

#### FACTORY ENSURED "COMPONENT COMPATIBILITY"

When using a complete Fall Protection System supplied by American Roof, Inc. dba / **SUPER ANCHOR SAFETY**, such as the "TOTAL PACKAGE" or "FALL ARRESTOR" Lifeline/Rope Grab system, component compatibility is ensured with the ARS 5K Anchor, provided the "USER" is in compliance with current Federal OSHA Fall Protection regulations, and uses the equipment in accordance with SUPER ANCHOR SAFETY, factory supplied Instruction/Specification manuals for all components being used. **Factory supplied instructions must be followed.**

#### USER ENSURED "COMPONENT COMPATIBILITY"

Components supplied by other manufacturers, mixed or matched, may be used provided the "USER" has component compatibility ensured by a "QUALIFIED" or "COMPETENT" person, and complies with the specifications for use of each component based on the factory or manufacturer supplied Instruction Manual and applicable OSHA Standards.

#### DEFINITIONS

References in this manual regarding safety standards are from CFR 29 Sub-Part (M) 1926;500-503. Individual State Plan requirements may vary from OSHA and the user must comply with any and all standards; either State or OSHA, that apply to the use of this device.

**NOTE:** Some states may not accept "FALL RESTRAINT" or "WORK POSITIONING" methods of Fall Protection.

#### COMPETENT PERSON:

Anyone capable of recognizing and evaluating employee exposure to hazardous or unsafe conditions and who has the authority to specify the necessary protective and precautionary measures to be implemented to ensure the safety of employees as required by OSHA regulations.

#### USER:

Anyone who purchases, specifies for use, employs workers, or uses this equipment for Fall Protection purposes.

#### FALL RESTRAINT OR WORK POSITIONING:

A method of personal Fall Protection that by limiting or restraining the worker, does not allow any exposure to a free fall.

#### HORIZONTAL LINE:

A line that is anchored at each end and runs parallel with the Ridge, Eave, or Roof Parapet which is used to attach a vertical Lifeline to restrain a worker.

#### APPROVED:

Equipment that is sanctioned, endorsed, accredited or certified, listed, labeled, or accepted by a duly constituted and nationally recognized authority or agency, as satisfactory for use in the specified manner.

#### COMPONENT COMPATIBILITY:

Components that are specifically designed to be used together as a complete Fall Protection System, that have been tested and/or certified for such use by a "QUALIFIED PERSON", and do not by their use together create a potential hazard or danger to the user.

#### TENSIONED VERTICAL LINE:

A line that is anchored at each end and is parallel with the Gable edge; or runs along the downward slope of a roof and is used to attach a Lanyard or short Lifeline for the purpose of restraining a worker.



**WARNING:**

THE IMPROPER USE OF ANCHORAGE DEVICES AND A FAILURE TO USE OTHER SAFETY EQUIPMENT COMPONENTS THAT ARE COMPATIBLE, MAY CREATE UNFORESEEN HAZARDS THAT COULD RESULT IN SERIOUS INJURY OR DEATH TO THE USER, IN THE EVENT OF A FALL.

THIS ANCHOR MUST ONLY BE INSTALLED ONTO RAFTERS WITH SHEATHING IN PLACE. DO NOT INSTALL OVER ROOFING MEMBRANES, SHEATHING PAPERS OR INSULATION.

## FRAMING ATTACHMENT REQUIREMENTS: Part 1

The ARS 5-K may be installed onto a rafter with sheathing at the Ridge, **Fig. 4**, or in the field area. **Fig. 3**, on a flat or sloped deck. Sheathing must conform to Part 11 on page 34. The anchor legs must be in line with the direction of slope as noted in **Figs. 2, 3, & 4** and properly centered over the rafter **Fig. 6-B**.

**WARNING:** THE ARS 5-K IS DESIGNED TO BE USED OVER FRAMING STRUCTURES THAT HAVE SHEATHING IN PLACE AND WHERE THERE IS NO DANGER OF FALLING THROUGH THE FRAMING TO A LOWER LEVEL. WHEN THIS TYPE OF WORK IS BEING DONE, IT IS RECOMMENDED THAT YOU USE THE ARS 2X8 ANCHOR WHICH BOLTS UNDER THE RAFTER.



**Fig. 1**

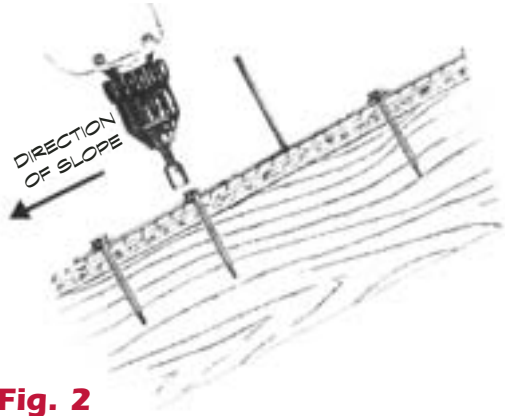

**Fig. 2**

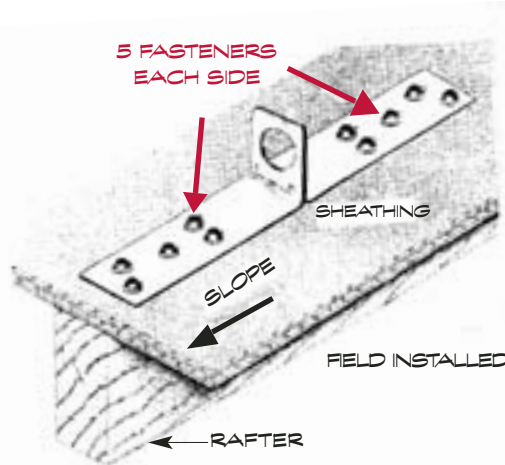

**Fig. 3**

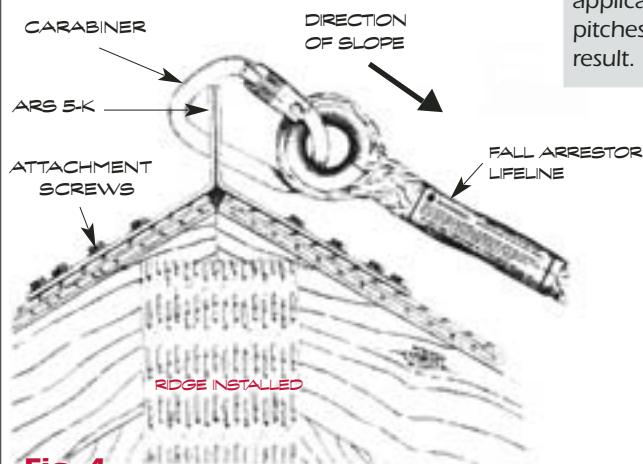

**Fig. 4**

## FASTENING REQUIREMENTS: Part 2

Each anchor is supplied with a "FACTORY FASTENER" package which includes 10 Each #12 x 2-7/8" Hex drive screws. All 10 Fasteners must be used to install the anchor as shown in **Fig. 3**. **DO NOT SUBSTITUTE MISSING FASTENERS WITH ANY OTHER TYPES OF SCREWS, BOLTS OR NAILS.**

**WARNING:** The "FACTORY SUPPLIED FASTENERS" are tested and certified to meet the pull out resistance requirements for use in "FALL ARREST" and "FALL RESTRAINT" applications. NEVER USE ANYTHING OTHER THAN THE "FACTORY SUPPLIED FASTENERS" Part #2009.

## MISSING FASTENERS OR REPLACEMENTS: Part 3

If the "FACTORY FASTENER" package is missing or you do not have the required 10 fasteners, DO NOT INSTALL THE ANCHOR until you have obtained a complete set from the distributor or the factory. Request Part #2009 Fastener package.

## FASTENING WITH NAILS/HAZARDOUS TO YOUR HEALTH!!!

Never for any reason, use nails to attach this anchor. Testing shows that most nails will pull out with less than 1,000 lbs. of force. In a free fall, you may exert more than 2 times that amount upon impact. If the anchor is attached with nails, it will be of no value in arresting a fall.

## METHOD OF INSTALLATION: Part 4

Each ARS 5-K 4-Pack (#1008), is supplied with a hex driver attachment #2010 for use with a cordless or power drill. Take care not to over-tighten the fasteners. Adjust the torque to snug the fasteners down to the surface of the anchor legs. **Fig. 2**. DO NOT USE A HAMMER TO INSTALL THE FASTENERS. Fasteners that are hammered in will extract at a much lower force. Hammering can weaken the fasteners and cause fracturing where the fastener head joins the threaded section. **Fig. 5**.

## REMOVING AN INSTALLED ANCHOR: Part 5

Anchors can be re-used as long as they are not damaged or have been subjected to a fall impact. **DO NOT RE-USE THE ORIGINAL FASTENERS.** Removing the attachment screws can cause unseen damage to the Stem/Hex head junction. Every time you re-use the anchor, use a new "FACTORY FASTENER" package #2009. **DISCARD ALL FASTENERS AFTER 1 USE.**

## BENDING THE ANCHOR TO ADJUST FOR PITCH: Part 6

ARS 5-K Anchors can be adjusted from flat to steep pitches. However, metal fatigue can result if this is done several times. To extend service life and reduce metal fatigue, it is recommended that you bend some anchors for low pitch applications and leave them that way. When fewer adjustments are made for pitches of 4/12 to a maximum 12/12, over a period of time less fatigue will result. See Part 17, "MAINTENANCE" regarding metal fatigue inspection.

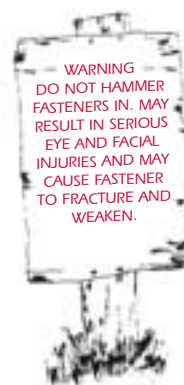
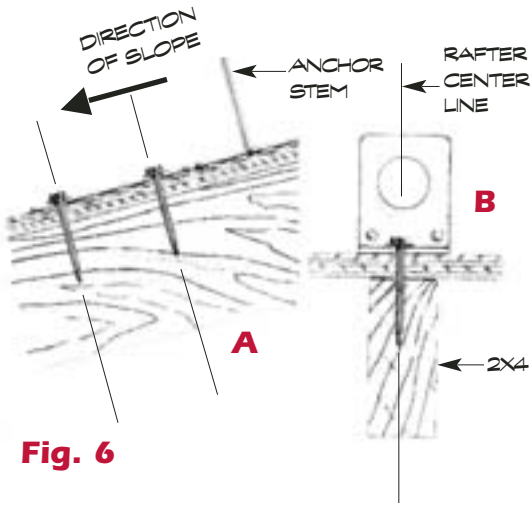

**Fig. 5**



**DO NOT  
HAMMER  
FASTENERS**

# ALIGNMENT OF FASTENERS



**Fig. 6**

## **FINDING THE RAFTER CENTER:** Part 7

The exact center of the rafter must be located and marked. The ARS 5-K Anchor must then be properly centered over the rafter center and all 10 fasteners must be used to install the anchor.

## **FASTENERS MISS THE RAFTER:** Part 8

If any of the fasteners miss the rafter, or are off-center as shown in **Fig. 8** below, then you must re-install the anchor at a new location at least 24" away from the original. Always use new fasteners.

## **ALIGNMENT OF FASTENERS IN THE RAFTER:** Part 9

Fasteners must be installed parallel to the rafter sides as shown in **Fig. 6-B** and 90° to the rafter or sheathing surface noted in **Fig. 6-A**. Fasteners installed at an angle, **Fig. 7**, may pull out in the event of a fall. If fasteners are improperly aligned, remove the anchor and move it to a new location at least 24" away from the original and use new fasteners.

## **DIRECTION OF SLOPE:** Part 10

The ARS 5-K Anchor must be installed so that the attachment legs and fasteners are in line, or parallel with the slope of the roof as shown in **Figs. 2, 3, & 4** on page 33. Note that in **Fig. 8-D** below, the anchor is improperly installed in the opposite direction of the slope.

## **FRAMING ATTACHMENTS AND SHEATHINGS:** Part 11

Do not attach the anchor to any framing that is not structural. This means that you must not install to any blocking, hip or ridge boards, or roof sheathings. The anchor may be installed into the rafter through sheathing boards, plywood, or OSB, that has a combined total thickness of 3/4" or less, **and fasteners must be properly aligned and extend fully into the rafter.**

## **HORIZONTAL LINES:** Part 12

The ARS 5-K is not specified for use as an anchorage point for any type of horizontal line configurations. Because tremendous forces are exerted in a free fall, we recommend that you consult with a structural engineer before attempting to implement any Horizontal Line system. **See Horizontal Line definition on Page 32.**

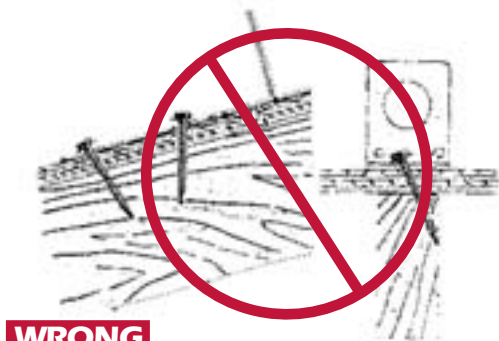

**WRONG**

**Fig. 7**

## **EXAMPLES OF WRONG INSTALLATION:** Part 13

**FAILURE TO PROPERLY CENTER THE FASTENERS IN THE RAFTER MAY CAUSE THE ANCHOR TO PULL OUT IN THE EVENT OF A FALL.**

**Fig. 8**

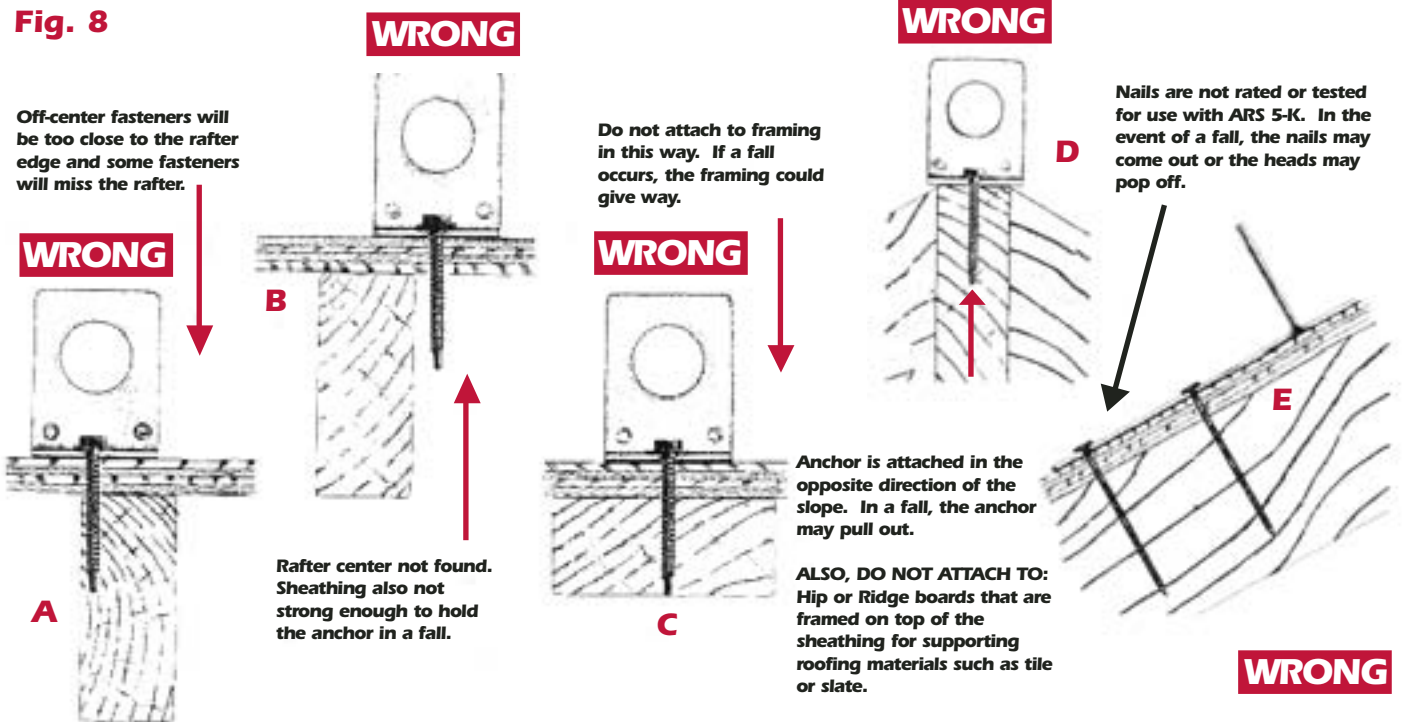

**Fig. 9**

# INSPECTION PROCEDURES

## INSTALLED ANCHORS: Part 14

- 1) Ensure that all 10 fasteners are in place and the washer part of the Hex Head is flush with the surface of the anchor leg. Factory fasteners are red in color.
- 2) Ensure that the anchor has been properly centered over the rafter center and that no fasteners have missed the rafter or blown out of the sides. Visually inspect the underside of the sheathing.
- 3) Make sure the sheathing and rafter are in sound condition and able to support the intended load. Do not install on damaged or rotten framing.

## EACH TIME YOU USE THE ANCHOR: Part 15

- 1) It is important to inspect installed anchors every time you use them. Roof traffic, material loading and handling, and other activity can cause damage to the anchor.  
**Always make sure:** **A)** All 10 fasteners are in place. **B)** Stem section is not flattened or damaged.

## WHEN A FALL OCCURS/DAMAGED ANCHOR: Part 16

If the anchor has been damaged, subjected to a fall impact, or the stem section has been flattened or crushed, do not use the anchor and do not attempt to repair it. Remove from service. Discard and replace with a new anchor in a different location.

## MAINTENANCE: Part 17

- 1) Inspect for metal fatigue at the stem to leg junction when anchors are frequently being bent back and forth to accommodate varying degrees of roof pitch. If small stretch marks or cracks appear, or if the two anchor sides are separated, or if the spot welds have been broken apart, remove the anchor from service.
- 2) If the warning label is not readable or has been damaged or removed, do not use the anchor until a new label is applied. See the Distributor or contact the factory.

## SPECIFIED CONNECTING HARDWARE: Part 18

There are only two types of connecting hardware that are specified for attaching a lifeline to the ARS 5-K Anchor. Locking Carabiner **Fig. 9-B**, and locking Snaphook **Fig. 9-A**. Do not tie a lifeline directly to the anchor as shown in **Fig. 9-C**. If a fall were to occur, the lifeline would be severed upon impact.

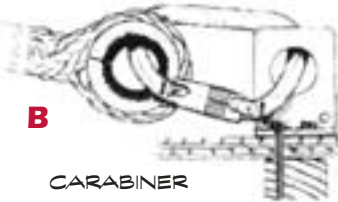
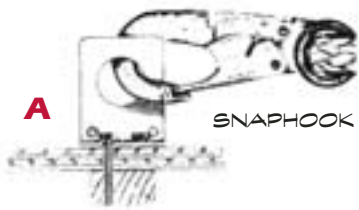

## REMOVING ANCHOR FROM SERVICE: Part 19

The ARS 5-K is not designed to be left in the roof system as a permanent fixture. It must be removed or disabled. Leaking around the stem and fastener penetrations will cause rotting of the framing, and create deadly safety hazards for any potential future users of the anchor.

## LEAVING THE ANCHOR IN THE ROOF: Part 20

The anchor can be left in the roof by flattening the stem section and then roofing over the anchor. If a smoother surface finish is desired, the anchor can be removed, or an opening can be cut in the sheathing over the rafter center (as long as there is no danger of falling through the framing) and the anchor installed directly to the framing. The anchor can then be flattened when through with it, and roofed over with no distortion to the membrane. Use filler if needed.

## - FALL ARREST AND ANCHOR LOCATION -

## ADJUSTING FOR MAXIMUM FREE-FALL DISTANCE: Part 21

When using the equipment shown in **Fig. 10**, the maximum allowable free-fall distance is 6 Ft. The limiter knot ("Fall Arrestor" system only), is used to gauge this distance. Take a position at the perimeter edge directly below the anchor point above. From the intersection of the rope grab knot and lifeline, measure out 6 Ft. of line and tie the limiter knot.

## EXCEEDING THE RANGE OF THE ANCHOR: Part 22

As the worker moves along the perimeter edge, the rope grab will intersect the "Limiter Knot". At this point, the range of the anchor (based on a 6 Ft. free-fall), is at its maximum point. The worker may move upslope or back toward the center point of the anchor. In order to work beyond the maximum anchor range point, a new anchor must be installed. **NOTE:** For rafters that are approximately 20 Ft. in length, anchors will be spaced about 32 Ft. on center. The shorter the rafter length, the closer together the anchors will be spaced.

## FALL PROTECTION EQUIPMENT: Part 23

SUPER ANCHOR SAFETY offers a complete line of "Personal Fall Protection" equipment and other Fall Arrest/Fall Restraint anchorage devices that are "Component Compatible" with the ARS 5-K. It is recommended that you use the "Total Package" system; which includes all of the components in **Fig. 10**, or the "Fall Arrestor" Lifeline/Rope Grab system. These components are designed primarily for roofing and residential construction work.

## SHOCK ABSORBERS: Part 24

A 6 Ft. free fall impact will generate about 2,500 lbs. of force. It can hurt. The use of a shock absorbing lanyard will reduce the impact of the force to 1,800 lbs. or less. As shown in our video, "Fall Protection for the Construction Industry", a worker can take a 6 Ft. free-fall or swing fall and sustain little or no injury. A shock absorbing lanyard is the best protection money can buy to ensure against free-fall injuries.

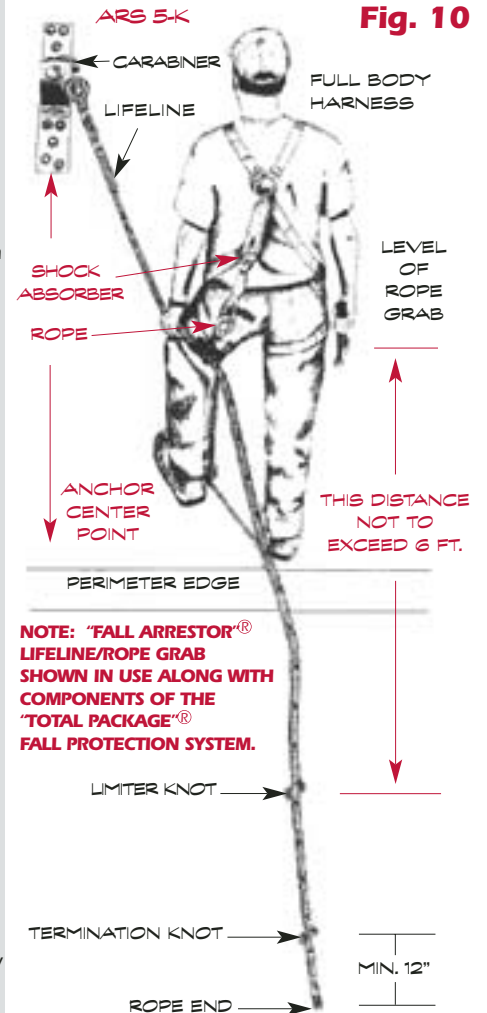

**NOTE: "FALL ARRESTOR"® LIFELINE/ROPE GRAB SHOWN IN USE ALONG WITH COMPONENTS OF THE "TOTAL PACKAGE"® FALL PROTECTION SYSTEM.**

# SUPER ANCHOR <sup>®</sup>

## ARS 3-K NON-REUSABLE ANCHOR

SURFACE MOUNTED / WORK POSITIONING / FALL RESTRAINT ANCHOR

### INSTRUCTION / SPECIFICATION MANUAL

#### TRAINING AND INSTRUCTION REQUIREMENTS:

ANYONE WHO USES SAFETY EQUIPMENT MUST FIRST RECEIVE TRAINING AND INSTRUCTION THAT MEETS THE REQUIREMENTS OF FEDERAL OSHA 1926.503 AND MUST COMPLY WITH THE INFORMATION CONTAINED IN THIS MANUAL.

#### USER COMPLIANCE

THE ARS 3-K IS DESIGNED TO BE USED AS A SINGLE PERSON ANCHORAGE POINT FOR "WORK POSITIONING / FALL RESTRAINT" METHODS OF FALL PROTECTION AND MEETS THE REQUIREMENTS OF FEDERAL OSHA 1926. 502(E) OF SUBPART M, WITH THE FOLLOWING EXCEPTION: **THE USER MUST NOT BE EXPOSED TO ANY FREE FALL HAZARDS.** SOME STATES MAY NOT ALLOW WORK POSITIONING / FALL RESTRAINT STANDARDS.

#### FACTORY ENSURED "COMPONENT COMPATIBILITY"

When using a complete fall protection system supplied by **SUPER ANCHOR SAFETY**, such as the "TOTAL PACKAGE" or "Fall Arrestor" Lifeline / Rope Grab system, component compatibility is ensured with the ARS 3-K anchorage device, provided the "User" is in compliance with current Federal OSHA fall protection regulations, and uses the equipment in accordance with **SUPER ANCHOR SAFETY** factory supplied Instruction / Specification Manuals. For all components, factory supplied instructions must be followed.

#### USER ENSURED "COMPONENT COMPATIBILITY"

Components supplied by other manufacturers mixed or matched, may be used provided the "User" has component compatibility ensured by a "Qualified" or "Competent" Person, and complies with the specifications for use of each component based on the factory or manufacturer supplied instruction manual, and applicable OSHA standards.

FIG. 1



FIG. 2

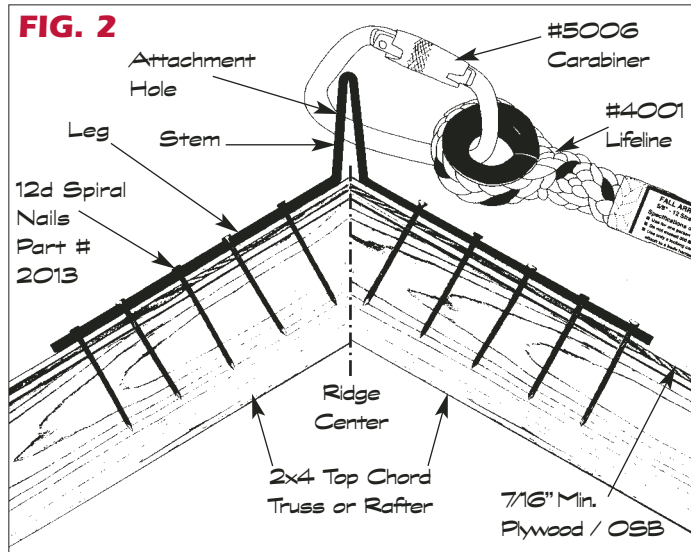

#### COMPETENT PERSON:

Anyone capable of recognizing and evaluating employee exposure to hazardous or unsafe conditions and capable of specifying the necessary protective and precautionary measures to be taken to ensure the safety of employees as required by OSHA regulations.

#### USER:

Anyone who purchases, specifies for use, employs workers, or uses this equipment for fall protection purposes.

#### COMPONENT COMPATIBILITY:

Components that are specifically designed to be used together as a complete fall protection system, that have been tested, and/or certified for such use by a "QUALIFIED PERSON," and do not by their use together create a potential hazard or danger to the user.

#### FALL RESTRAINT OR WORK POSITIONING:

A method of personal fall protection that by limiting or restraining the worker, does not allow any exposure to a free fall.

### THE ARS 3-K ANCHOR MUST BE USED IN ACCORDANCE WITH THE FOLLOWING SPECIFICATIONS:

- 1.0 Ridge mounted only. See Fig. 2.
- 1.1 Used with a shock absorbing lanyard in compliance with 1926;502 (d)(16)(ii) which limits maximum arresting force on a worker to 1,800 lbs. or less.
- 1.2 Must not be used on roof slopes greater than 8/12 pitch. (33.5° angle)
- 1.3 Must not be used over roofing membranes, insulation, or sheathing papers.

### ATTACHING / INSTALLING ANCHOR TO FRAMING: Part 1

The ARS 3-K anchor must be installed onto a rafter that has a minimum sheathing thickness of 7/16" either O.S.B. or plywood. The center of the anchor legs must line up over the center of the rafter and the anchor stem must be centered over the ridge apex. See Fig. 2, 3a, & 3b.

The ARS 3-K is pre-bent to fit a 5/12 pitch. Before installing fasteners, bend the anchor legs to conform to the pitch or slope of the structure to which the anchor will be attached.



THE IMPROPER USE OF ANCHORAGE DEVICES AND A FAILURE TO USE OTHER SAFETY EQUIPMENT COMPONENTS THAT ARE COMPATIBLE, MAY CREATE UNFORESEEN HAZARDS THAT COULD RESULT IN SERIOUS INJURY OR DEATH TO THE USER, IN THE EVENT OF A FALL.

## FASTENERS: Part 2

Each anchor requires 10 factory supplied 9 gauge - 12d spiral Stainless steel nails, which are included with the anchor package. **DO NOT SUBSTITUTE OR USE ANY OTHER TYPE OF FASTENERS.**

Make sure you have enough factory supplied nails before installing the anchor. If the factory supplied nails are missing, or you do not have the required 10 nails, do not install the anchor until you have obtained the factory supplied fasteners. **Request replacement Part #2013 for use with the ARS 3-K.**

## METHOD OF INSTALLATION: Part 3

### ANCHOR POSITIONING:

Once the 3-K legs have been bent to conform to the roof pitch, set anchor over the center of the ridge with the center of the anchor leg directly over the center of the rafter. See **Fig. 3b**. Follow the nail hole indicators shown on the warning label as a guide for alignment. See **Fig. 3a**. Install fasteners by hammering. **Always wear eye protection when hammering. Do not install anchor if warning label is missing.**

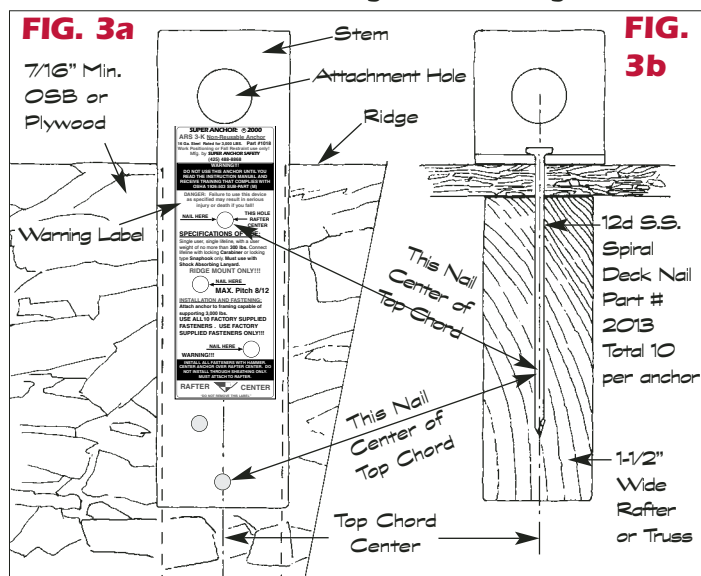

## USE BY WORKER: Part 4

No more than one person may be connected to the 3-K anchor, with a maximum user weight of 300 lbs. which includes all tools, equipment, and materials being carried, etc. Do not use when wind velocity exceeds 90 MPH or when golf ball size hail is present.

Do not use as a component of a horizontal line system, or for any other purpose other than personal fall protection as a positioning device. Must be used in compliance with OSHA 1926.502(e) with the following exception: **THE WORKER MUST NOT BE EXPOSED TO ANY FREE FALL HAZARDS.**

## INSPECTION BEFORE USE: Part 5

Visually inspect the anchor before use to ensure proper installation and component integrity. From the underside of the sheathing, observe that none of the nails have missed the truss or rafter top chord, or are protruding from the sides of the rafter. From the top side, make sure all 10 factory fasteners are in place and driven down so the heads are flush with the surface of the anchor leg. Inspect the stem for deformation, such as being bent over or twisted, and inspect the stem attachment hole for any signs of damage, tearing, or deformation. If all requirements of installation are present with no defects, the anchor may be used.

## DAMAGED ANCHOR OR Part 6

### IMPROPER INSTALLATION:

**DO NOT USE WHEN THE FOLLOWING CONDITIONS ARE OBSERVED!!!**

#### Fasteners:

- A** - If fasteners protrude through the sides of the top chord or sheathing. See **Fig. 4b**.
- B** - If fasteners are bent over or not driven flush with the surface of the anchor leg. See **Fig. 4a & 4c**.
- C** - Less than 5 fasteners in each leg
- D** - If non-factory supplied fasteners are used, or heads are missing. **(Use factory fastener for comparison)**

#### Position or location:

- E** - If anchor is not mounted on center of ridge See **Fig. 2**.
- F** - If anchor leg is not centered over rafter center See **Fig. 4c & 4d**.
- G** - If anchor is installed directly to a rafter without sheathing

#### Anchor integrity:

- H** - If anchor stem is flattened or bent over
- I** - If attachment hole is torn, twisted, or deformed in any way

**WARNING:** Once the stem section has been bent over, do not attempt to re-bend it back to its original shape. Structural defects may result causing the anchor strength to be greatly reduced.

## REMOVING FROM SERVICE Part 7

### WHEN WORK IS COMPLETED:

Disable or remove the anchor by bending or flattening the stem and roofing over it. If the anchor is removed from its installation, discard the anchor and fasteners in a way that ensures it can not be used again.

### COMPONENT INSPECTION BEFORE USE:

Before installing, inspect each anchor for defects. Damage can occur due to shipping, storage, or abuse. Install anchors that are free of defects, have the factory warning label on one leg, and are furnished with one set of 10 factory fasteners, and have never been used before. Evidence of previous use may be determined by surface scratching of the warning label, oxidation (rust) or deformation of the stem section.

### CONNECTING HARDWARE:

A single lifeline or lanyard is connected to the stem attachment hole using a locking type carabiner or locking snap hook which is specified for fall protection use.

## EXAMPLES OF WRONG INSTALLATION: Part 8

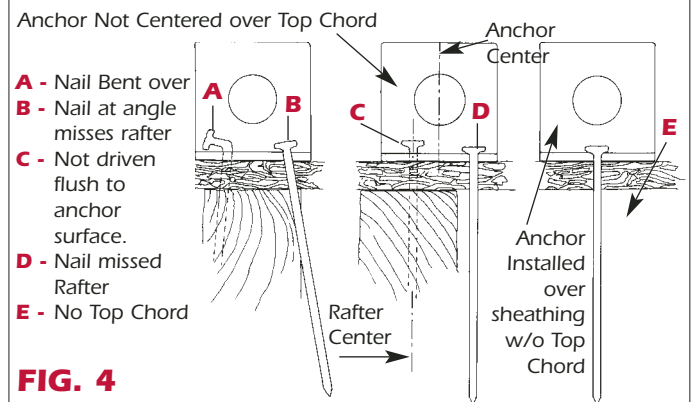

### WRONG ALIGNMENT / NAILING

**Warning:** If anchor is not centered over the rafter, nails protrude through the rafter side, or if nails penetrate only the sheathing, the anchor may pull out in the event of a fall.

# **SUPER ANCHOR<sup>®</sup>**

## **UNIVERSAL ANCHOR**

### **SURFACE MOUNTED/FALL ARREST ANCHOR**

### **INSTRUCTION/SPECIFICATION MANUAL**

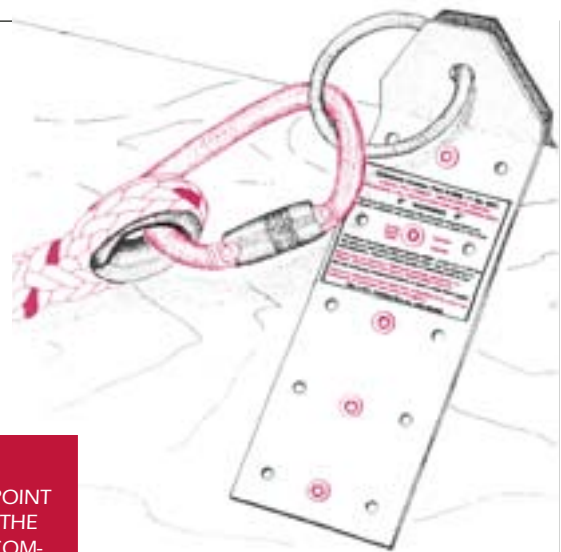

#### **TRAINING AND INSTRUCTION REQUIREMENTS:**

ANYONE WHO USES SAFETY EQUIPMENT MUST FIRST RECEIVE TRAINING AND INSTRUCTION THAT MEETS THE REQUIREMENTS OF FEDERAL OSHA 1926.503 AND COMPLIES WITH THE INFORMATION CONTAINED IN THIS MANUAL.

#### **USER COMPLIANCE**

THE UNIVERSAL ANCHOR IS DESIGNED TO BE USED AS A SINGLE PERSON ANCHORAGE POINT FOR "FALL ARREST" AND "FALL RESTRAINT" METHODS OF FALL PROTECTION AND MEETS THE REQUIREMENTS OF FED. OSHA 1926.502(D) OF SUBPART M. THE USER MUST ENSURE COMPONENT COMPATIBILITY WITH A FULL BODY HARNESS, SHOCK ABSORBING LANYARD, OR STRAIGHT LANYARD, LIFELINE, ROPE GRAB DEVICE, AND CONNECTING HARDWARE.

#### **FACTORY ENSURED "COMPONENT COMPATIBILITY"**

WHEN USING A COMPLETE FALL PROTECTION SYSTEM SUPPLIED BY SUPER ANCHOR SAFETY, SUCH AS THE "TOTAL PACKAGE" OR "FALL ARRESTOR" LIFELINE/ROPE GRAB SYSTEM, COMPONENT COMPATIBILITY IS ENSURED WITH THE UNIVERSAL ANCHOR. FACTORY SUPPLIED INSTRUCTIONS MUST BE FOLLOWED.

#### **USER ENSURED "COMPONENT COMPATIBILITY"**

COMPONENTS SUPPLIED BY OTHER MFG. MIXED OR MATCHED, MAY BE USED PROVIDED THE "USER" HAS COMPONENT COMPATIBILITY ENSURED BY A "QUALIFIED" OR "COMPETENT" PERSON.

**WARNING: THE UNIVERSAL ANCHOR MUST BE INSTALLED OVER SHEATHING. DO NOT ATTACH DIRECTLY TO A BARE RAFTER OR TRUSS.**

#### **FRAMING ATTACHMENT REQUIREMENTS PART # 1**

Attach the Universal Anchor to the following types of framing or sheathings, unless prohibited by local building codes or safety standards, and are free of damage, defects, and have not been exposed to the weather for more than 10 days, and are not moisture saturated.

#### **FRAMING:**

Must be at least a 2x4 truss or rafter, with sheathing and capable of supporting a 5,000 lb. load for fall arrest use, and a 3,000 lb. load for fall restraint use. **DO NOT EXCEED 12/12 PITCH OR 45 DEGREE ANGLE.**

#### **SHEATHINGS:**

Must be at least 7/16" thick, OSB or 4-ply Plywood, attached to the framing per current UBC standards.

#### **ASPHALT ROOFING/BUILT-UP ROOFING:**

Anchor may be attached through no more than 1 layer of roofing, which is installed over sheathing with no insulations, furring, or fillers. Fasteners must penetrate the underside of the sheathing a minimum of 3/4".

#### **FASTENERS:**

Use only factory supplied fasteners that are unused and in unopened packages, that are specified for the type of installation shown on page 3&4. Do not substitute with generic types. **WARNING: Fasteners must be replaced with new, each time the anchor is installed.**

**FACTORY SUPPLIED FASTENERS ARE TESTED AND CERTIFIED FOR USE WITH THE UNIVERSAL ANCHOR ONLY.**

#### **INSTALLATION OF THE ANCHOR:**

When using screws, always install with a screw gun or drill, and hex driver. **DO NOT HAMMER IN SCREWS.** This may cause fracturing and failure of the fasteners. Always wear eye protection when installing. **INSTALL PARALLEL TO SLOPE OF ROOF OR RAFTER.**

#### **REMOVING INSTALLED ANCHOR:**

Remove screws using same method as installation. **DO NOT PULL OUT BY PRYING THE UNDERSIDE OF THE ANCHOR.** This will cause deformation and possible fracture or damage to the anchor.

#### **INSPECTION:**

Always inspect the rafters and sheathing before installing to ensure integrity. Also inspect after fasteners have been installed to ensure proper penetration and alignment.

#### **MAINTENANCE:**

Inspect the anchor every time you use it. The warning label must be intact, all required fasteners in place, and the anchor must be free of bends, cracks, or defects.

#### **WHEN A FALL OCCURS:**

Remove and replace the anchor if it has been subjected to any kind of damage or a fall. The attachment ring will elongate or become oval in shape when subjected to a force of 900 lbs. or more. If the attachment ring is not perfectly round, remove the anchor from service and replace.



THE IMPROPER USE OF ANCHORAGE DEVICES AND A FAILURE TO USE OTHER SAFETY EQUIPMENT COMPONENTS THAT ARE COMPATIBLE, MAY CREATE UNFORESEEN HAZARDS THAT COULD RESULT IN SERIOUS INJURY OR DEATH TO THE USER, IN THE EVENT OF A FALL.

# APPROVED CONNECTORS

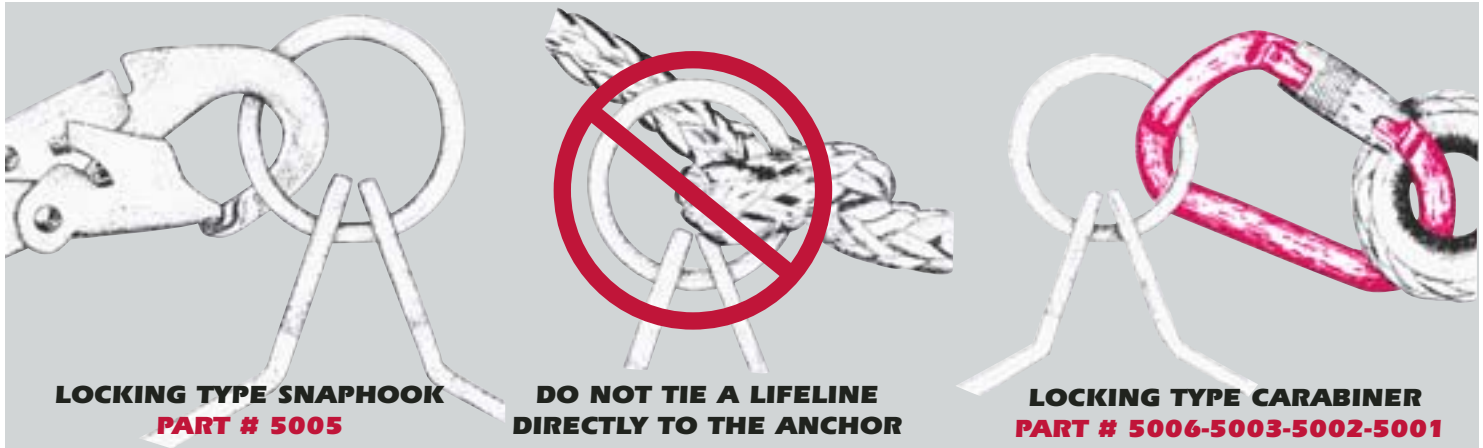

**LOCKING TYPE SNAPHOOK  
PART # 5005**

**DO NOT TIE A LIFELINE  
DIRECTLY TO THE ANCHOR**

**LOCKING TYPE CARABINER  
PART # 5006-5003-5002-5001**

## VISUAL INSPECTION OF ANCHOR

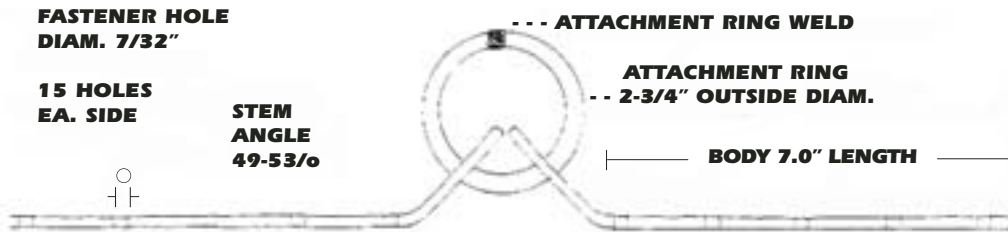

### ANCHOR INSPECTION:

- 1) ATTACHMENT RING MUST BE ROUND, WITH NO VISIBLE SIGNS OF DISTORTION.
- 2) ATTACHMENT RING WELD. MUST BE UNBROKEN WITH NO SIGNS OF CRACKING.
- 3) ANCHOR STEM/BODY MUST HAVE NO SIGNS OF BENDING CRACKING OR MODIFICATION, WARNING LABEL IS INTACT AND READABLE.

### ATTACHMENT RING

**WELD IS BROKEN  
OR CRACKED**

**ANCHOR BODY IS BENT**

**LENGTH HAS BEEN SHORTENED, WELDED,  
OR MODIFIED IN SOME WAY.**

**-- OVAL SHAPE OF RING INDICATES  
LOADING OR DAMAGE.**

**-- NORMAL SHAPE IS PERFECTLY  
ROUND**

**STEM ANGLE IS MORE OR LESS  
THAN 49-53/°**

**FASTENER HOLES HAVE  
BEEN ENLARGED MORE  
THAN 7/32"**

### DOES NOT PASS INSPECTION

**WARNING: DO NOT ATTEMPT TO MODIFY OR CHANGE THE ANCHOR IN ANY WAY. DO NOT ATTEMPT TO REPAIR BY REFORMING OR WELDING. DO NOT ENLARGE FASTENER HOLES, SHORTEN THE STEM LENGTH/WIDTH. DO NOT USE FOR ANY OTHER PURPOSE THAN FALL PROTECTION.**

### DO NOT USE ANCHOR:

- 1) ATTACHMENT RING IS DISTORTED OR OVAL SHAPE, RING WELD IS CRACKED.
- 2) ANCHOR STEM/BODY IS DISTORTED, BENT, OR MODIFIED FROM ITS SPECIFIED DIMENSION IN ANY WAY. WARNING LABEL IS MISSING, DAMAGED, OR CANNOT BE READ.

### DAMAGED ANCHOR:

**DAMAGED ANCHORS MUST BE REMOVED FROM SERVICE AND DISPOSED OF**

### AUTHORIZED FACTORY REPAIR:

**THE WARNING LABEL MAY BE REPLACED BY RETURNING THE ANCHOR TO THE FACTORY. NO OTHER REPAIR OR SERVICE IS OFFERED.**

**MAY BE INSTALLED ON A FLAT  
SURFACE**

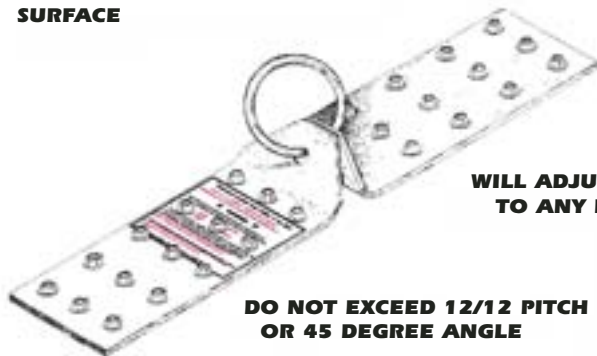

### ALIGNMENT TO RAFTER AND SLOPE

**ANCHOR MUST ALWAYS BE  
INSTALLED  
PARALLEL WITH SLOPE,  
TRUSS, OR, RAFTER RUN.**

**RAFTER/TRUSS  
UNDER SHEATHING**

**DIRECTION OF  
SLOPE**

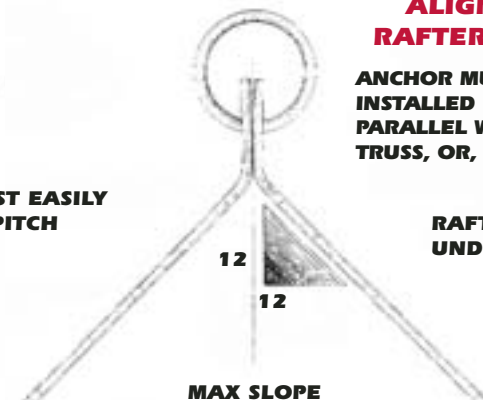

# ANCHOR FASTENING GUIDE

## INTO RAFTER W/SCREWS

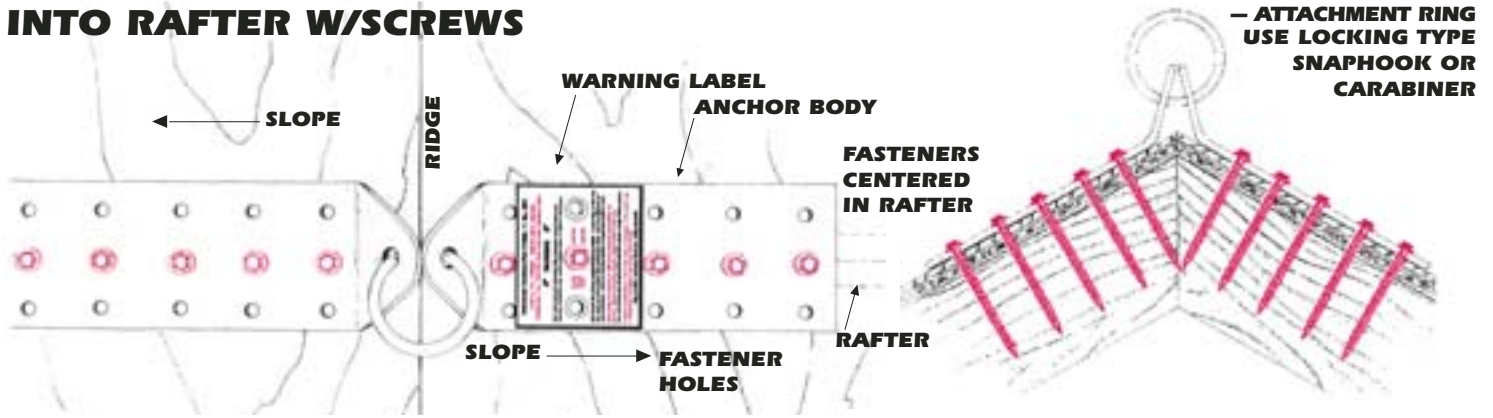

## INTO RAFTER W/DUPLEX NAILS

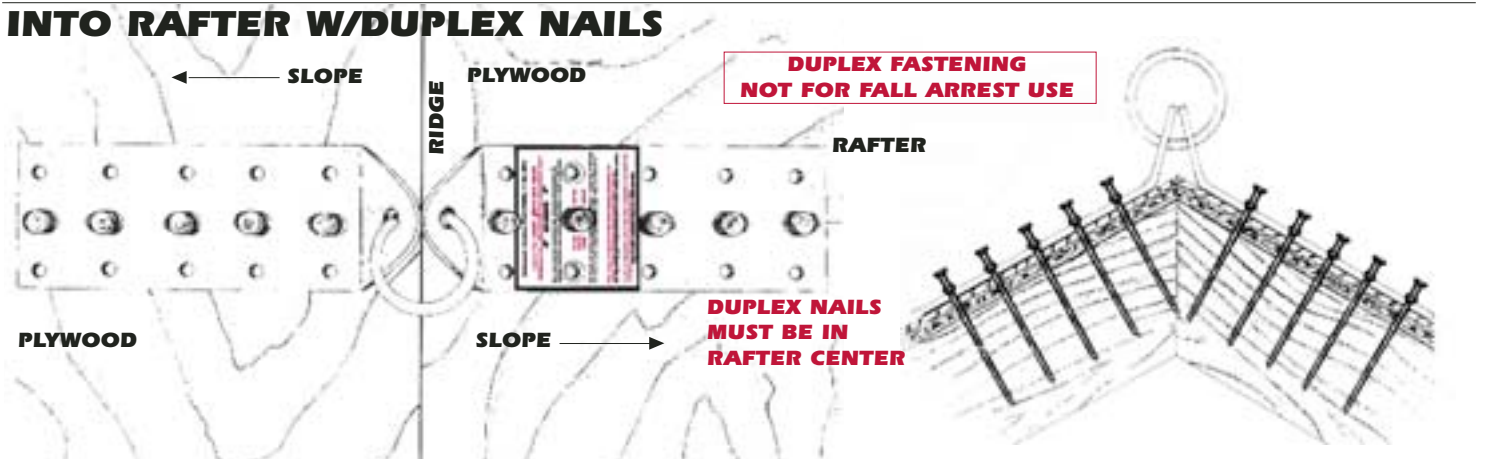



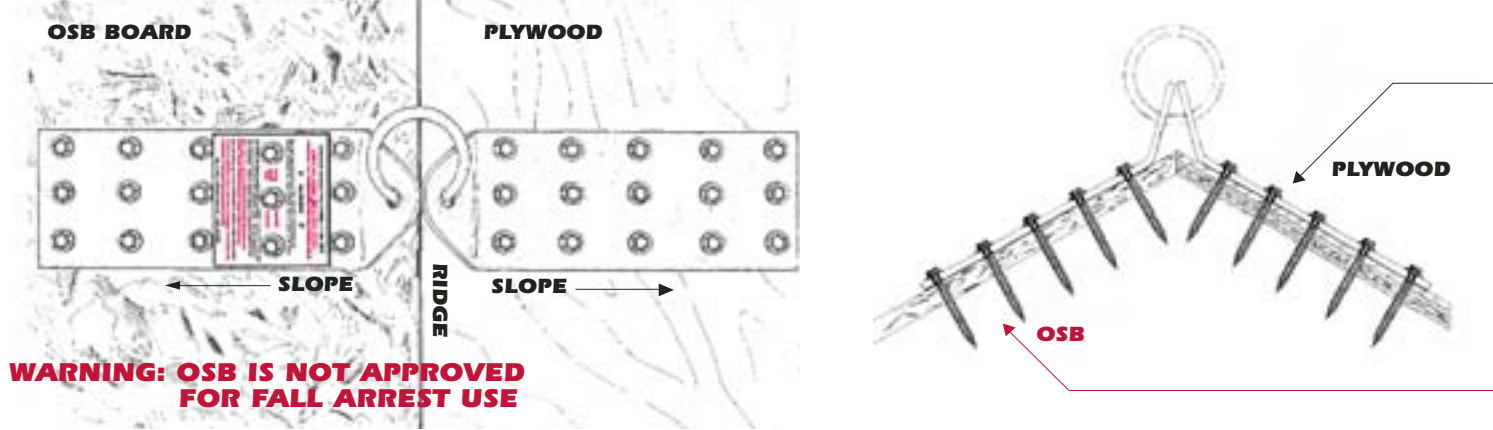

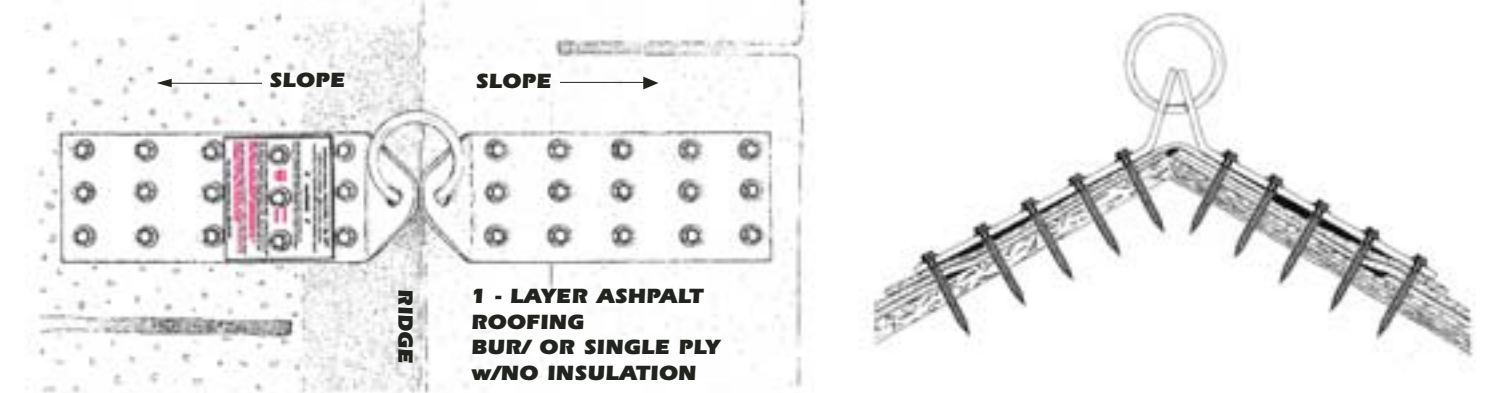

## THROUGH SHEATHING OSB/PLYWOOD

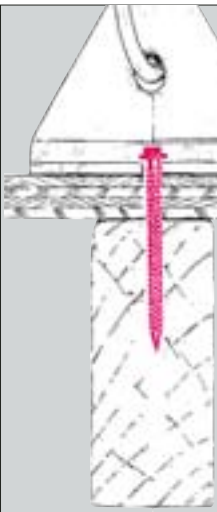

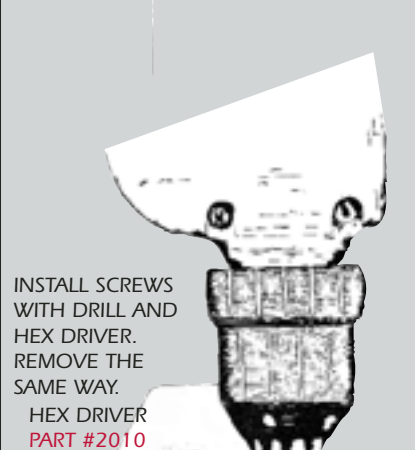
## THROUGH 1 LAYER ASPHALT ROOFING

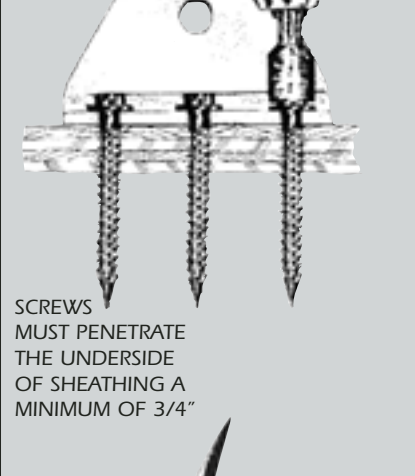

METHOD OF FALL PROTECTION	FASTENER SPECIFICATION	FACTORY FASTENER PACKAGE	
<p><b>FALL ARREST</b> <b>1 PERSON</b></p> <p><b>5,000 LB. RATED</b></p>	<p>RED COLOR HEX HEAD SCREW</p> <p>2-7/8" LENGTH</p> <p>10 SCREWS 5 EACH SIDE IN CENTER OF RAFTER</p>	<p><b>PART # 2009</b> 10 - #12 x 2-7/8" Red Hex Head Screws</p> 	 <p>USE MIDDLE ROW OF FASTENER HOLES</p> <p>MUST HAVE SHEATHING OVER RAFTER</p> <p>SCREWS MUST BE CENTERED IN THE RAFTER</p>
<p><b>FALL RESTRAINT OR WORK POSITIONING</b> <b>1 PERSON</b></p> <p><b>3,000 LB. RATED</b></p>	<p>DUPLEX NAIL 16d UNCOATED</p> <p>10 NAILS 5 EACH SIDE IN CENTER OF RAFTER</p>	<p><b>PART # 2012</b> 10 - 16d DUPLEX Uncoated Nail</p> 	 <p>INSTALL SCREWS WITH DRILL AND HEX DRIVER. REMOVE THE SAME WAY.</p> <p>HEX DRIVER <b>PART #2010</b></p>
<p><b>FALL ARREST</b> <b>1 PERSON</b> <b>5,000 LB. RATED</b></p> <p><b>7/16" 4-Ply Plywood</b></p> <p><b>FALL RESTRAINT OR WORK POSITIONING</b> <b>1 PERSON</b> <b>3,000 LB. RATED</b></p> <p><b>7/16" OSB BOARD</b></p>	<p>BLACK COLOR HEX HEAD SCREW</p> <p>1-5/8" LENGTH</p> <p>30 SCREWS 15 EACH SIDE PENETRATE SHEATHING A MIN. OF 3/4" THROUGH UNDERSIDE</p>	<p><b>PART # 2011</b> 30 - #12 x 1-5/8" Black Hex Head Screws</p> 	 <p>SCREWS MUST PENETRATE THE UNDERSIDE OF SHEATHING A MINIMUM OF 3/4"</p>
<p><b>FALL RESTRAINT OR WORK POSITIONING</b> <b>1 PERSON</b></p> <p><b>3,000 LB. RATED</b></p>	<p>BLACK COLOR HEX HEAD SCREW</p> <p>1-5/8" LENGTH</p> <p>30 SCREWS 15 EACH SIDE PENETRATE SHEATHING A MIN. OF 3/4" THROUGH UNDERSIDE</p>	<p><b>PART # 2011</b> 30 - #12 x 1-5/8" Black Hex Head Screws</p> 	 <p>DO NOT HAMMER IN SCREWS</p>

# SUPER ANCHOR<sup>®</sup> MOVEABLE ARS ANCHOR

TEMPORARY FALL PROTECTION  
ANCHORAGE DEVICE

## SUPPLEMENTAL INSTRUCTIONS

### TRAINING AND INSTRUCTION REQUIREMENTS:

ANYONE WHO USES SAFETY EQUIPMENT MUST FIRST RECEIVE TRAINING AND INSTRUCTION THAT MEETS THE REQUIREMENTS OF FEDERAL OSHA 1926.503 AND COMPLIES WITH THE INFORMATION CONTAINED IN THIS MANUAL

### USER COMPLIANCE

THE MOVEABLE ARS ANCHOR IS DESIGNED TO BE USED AS A SINGLE PERSON ANCHORAGE POINT FOR "FALL ARREST" AND "FALL RESTRAINT" METHODS OF FALL PROTECTION AND MEETS THE REQUIREMENTS OF FED. OSHA 1926.502(D) OF SUBPART M. THE USER MUST ENSURE COMPONENT COMPATIBILITY WITH A FULL BODY HARNESS, SHOCK ABSORBING LANYARD, OR STRAIGHT LANYARD, LIFELINE, ROPE GRAB DEVICE, AND CONNECTING HARDWARE.

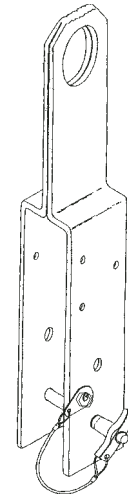

Fig. 1

### FACTORY ENSURED "COMPONENT COMPATIBILITY"

WHEN USING A COMPLETE FALL PROTECTION SYSTEM SUPPLIED BY SUPER ANCHOR SAFETY, SUCH AS THE "TOTAL PACKAGE" OR "FALL ARRESTOR" LIFELINE/ROPE GRAB SYSTEM, COMPONENT COMPATIBILITY IS ENSURED WITH THE MOVEABLE ARS ANCHOR. FACTORY SUPPLIED INSTRUCTIONS MUST BE FOLLOWED.

### USER ENSURED "COMPONENT COMPATIBILITY"

COMPONENTS SUPPLIED BY OTHER MFG. MIXED OR MATCHED, MAY BE USED PROVIDED THE "USER" HAS COMPONENT COMPATIBILITY ENSURED BY A "QUALIFIED" OR "COMPETENT" PERSON.

### THE FOLLOWING INSTALLATION CONDITIONS MUST BE MET BEFORE USING THE MOVEABLE ARS ANCHOR AS AN ANCHORAGE DEVICE:

- 1) Must be attached to rafter with locking pin engaged and in the locked position. See Fig. 3-6 on Page 43.
- 2) Correct size anchor must be used for specified rafter size.  
**Part #1014** For 2x4, 2x6, or 2x8  
**Part #1015** For 2x10 or 2x12

### FRAMING REQUIRED:

3) Use the moveable ARS Anchor only on framing that meets or exceeds the requirements of current uniform building code, us STD-Better #1 Grade, free of defects, cracks, damage and is not a spliced member, and has not been exposed to the weather for more than 30 days.

### STRUCTURAL BRACING:

4) Attach the Moveable ARS Anchor to a wood framed structure that is capable of supporting the intended load for Fall Arrest or Work Positioning use. Temporary structural bracing of walls, rafters, or trusses; or other framed components may be required. This manual makes no recommendation regarding structural bracing.

### DEFINITIONS:

#### OUTSIDE VERTICAL FALL:

A fall that occurs to the outside of an exterior wall or similar framing configuration where the primary forces applied to the rafter, truss, or joist are in tension.

#### INSIDE VERTICAL FALL:

A fall between the wall top plate or similar framing configuration and the Moveable ARS Anchor position on the rafter, truss, or joist, resulting in a downward deflection of that framing member.

#### SWING FALL:

A fall that is off center from the attachment stem on the Moveable ARS Anchor, resulting in a pendulum motion.

#### CROSS BRACING:

Lateral cross bracing is required between the worker's position and the Moveable ARS Anchor prior to roof sheathing installation, to act as a catch for the lifeline or lanyard; anytime there is an exposure to an inside vertical fall, or when cross grain forces create deflection in the rafter, truss, or joist.

#### FALL HAZARD EXPOSURE:

Any exposure to a fall that is defined by Federal OSHA or state safety regulations, including those defined by company or individual Fall Protection programs.



THE IMPROPER USE OF ANCHORAGE DEVICES AND A FAILURE TO USE OTHER SAFETY EQUIPMENT COMPONENTS THAT ARE COMPATIBLE, MAY CREATE UNFORESEEN HAZARDS THAT COULD RESULT IN SERIOUS INJURY OR DEATH TO THE USER, IN THE EVENT OF A FALL.

# INSTALLATION PROCEDURE:

## RAFTER, TRUSS CONFIGURATIONS

**Fig. 2**

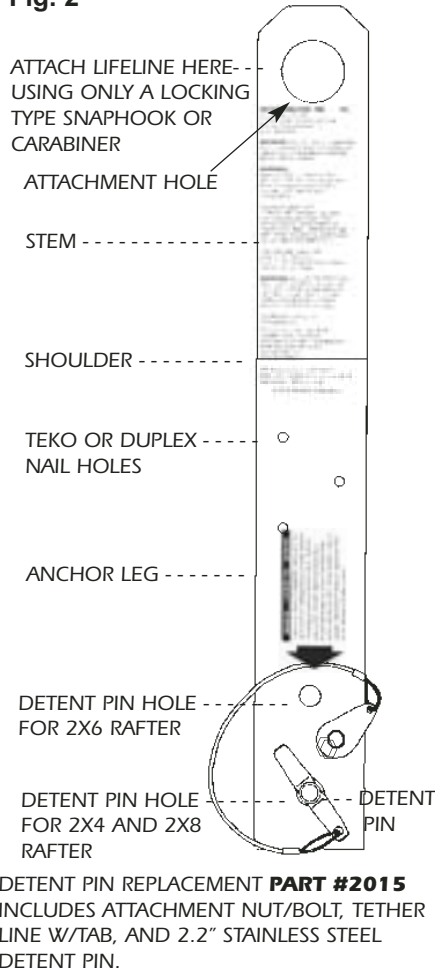

**WARNING:** THE ANCHOR MAY MOVE POSITION ON THE RAFTER WHEN SUBJECTED TO A FALL. USE A 16d DUPLEX NAIL ON EACH SIDE OF THE ANCHOR TO PREVENT ANY SLIPPING.

**Fig. 3**

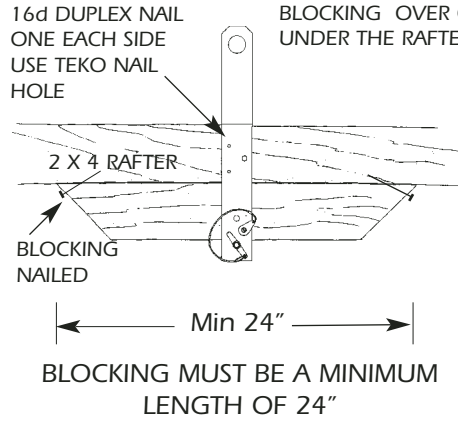

**IMPORTANT**  
2X4 RAFTER REQUIRES BLOCKING OVER OR UNDER THE RAFTER

**Fig. 4**

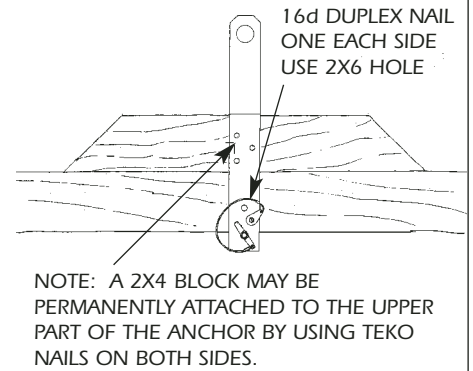

**Fig. 5**

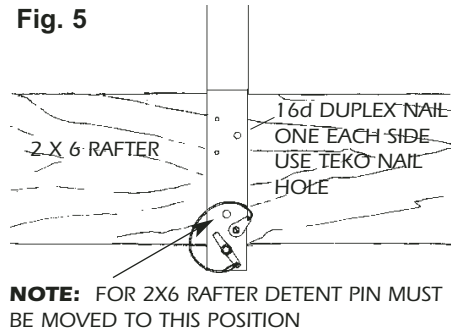

**Fig. 6**

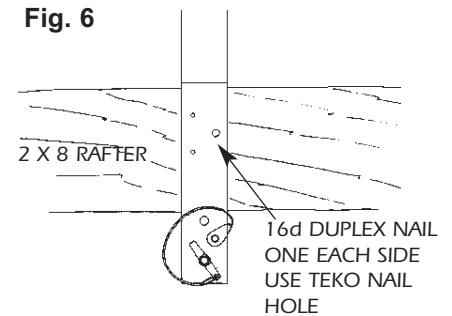

### DETENT LOCKING PIN

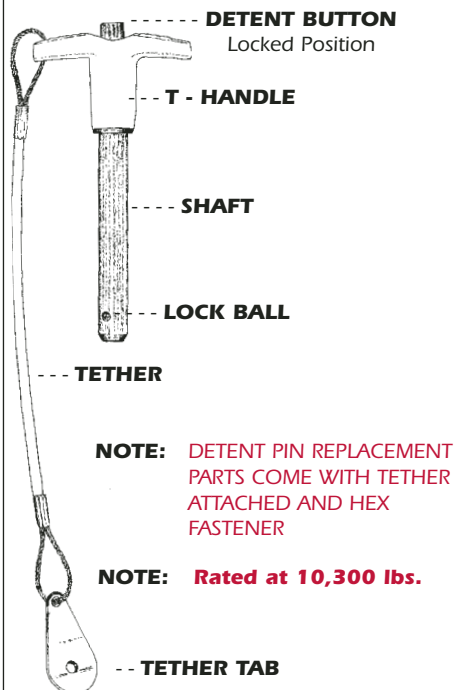

### DETENT LOCKING PINS:

The Moveable ARS Anchor is equipped with a **Detent Locking Pin, rated at 10,300 lbs.** Pins must be inserted through the leg holes and remain in the locked position when in use for Fall Protection, as shown in **Fig. 3-6** above.

### INSERTING DETENT LOCKING PINS:

Grasp the **T-Handle** and hold the **Detent Button** down in the **"Unlocked"** position by depressing. Insert the pin through the leg pin holes until the locking balls are visible on the outside of the leg face. Release the detent button. The pin is now in its **"Locked"** position and should not be able to be pulled out.

### CHECKING DETENT PIN FUNCTION:

Detent locking pins are held in their locked position by 2 **Locking Balls**, located on the bottom of the pin shaft, opposite each other. Depressing the pin button activates a spring that allows the pin balls to retract inside the pin shaft. This is the **"Unlocked"** position. Releasing the Detent Button forces the locking balls into their **"Locked"** position. Check the function by pushing the detent button down several times and observing the locked position. The pin should not be able to be pulled out of the leg pin holes.

### PIN DOES NOT FUNCTION PROPERLY:

If the detent pin will not remain in the locked position, is damaged, or is subjected to a fall impact, **DO NOT USE THE MOVEABLE ARS ANCHOR.** Locking pins must be replaced with a factory supplied part only. **DO NOT SUBSTITUTE WITH ANY OTHER TYPE OF PIN OR FASTENER.**

# SUPER ANCHOR<sup>®</sup> RetroFit Anchor

## INSTRUCTION/SPECIFICATION MANUAL

### PACKAGE CONTENTS:

- 1 RetroFit Anchor w/waterproof membrane strip
- 8 Stainless Spiral Nails
- This Instruction Manual

### SPECIFICATION OF USE:

Designed primarily for use with asphalt or wood shingle/shake roofing with standard or vented type ridge systems.

### ANCHOR USE SPECIFICATION:

May be used for Fall Arrest or Work Positioning. Rated for a 5,000 lb. load when 8 factory supplied fasteners are used in accordance with these instructions.

### MATERIAL SPECIFICATION:

20 Ga. #304 Stainless Steel. 14" length x 1-3/4" width. Fitted with 2 Ea. 5,000 lb. rated die chromate coated D-Rings. Waterproof membrane 2" x 10" x (thickness) butyl strip.

### FRAMING REQUIREMENTS:

The anchor must be installed into a minimum 2x4 top chord rafter or truss with a minimum sheathing thickness of 7/16" OSB or plywood. The supporting structure must be capable of withstanding twice the intended fall impact load.\* The top chord must be solid with no defects such as rotting or cracking; and a minimum of #2 Douglas Fir or equal.

### INSTALLATION PROCEDURE:

The center of the anchor must be centered over the top chord as shown in **Fig. 1a & 1b**. The anchor center is designated by the first and last nail hole on each side as shown in **Fig. 1**. Each anchor side has four nail positions, all of which must be secured with the factory supplied fasteners. Fasteners must penetrate a minimum of 1-3/4" (inches) into the top chord or rafter. The total fastener length will allow approximately 1-1/4" of additional thickness of sheathing and roofing membrane.

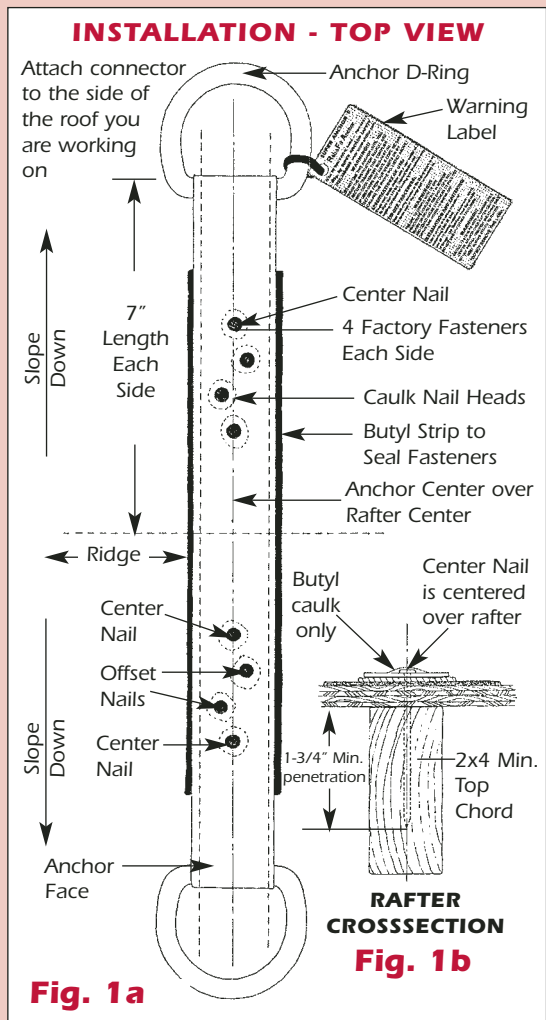

**Fig. 1a**

**Fig. 1b**



### WARNING:

THE IMPROPER USE OF ANCHORAGE DEVICES AND A FAILURE TO USE OTHER SAFETY EQUIPMENT COMPONENTS THAT ARE COMPATIBLE, MAY CREATE UNFORESEEN HAZARDS THAT COULD RESULT IN SERIOUS INJURY OR DEATH TO THE USER, IN THE EVENT OF A FALL.

### RETRO-FIT STRAP ANCHOR Installation Detail

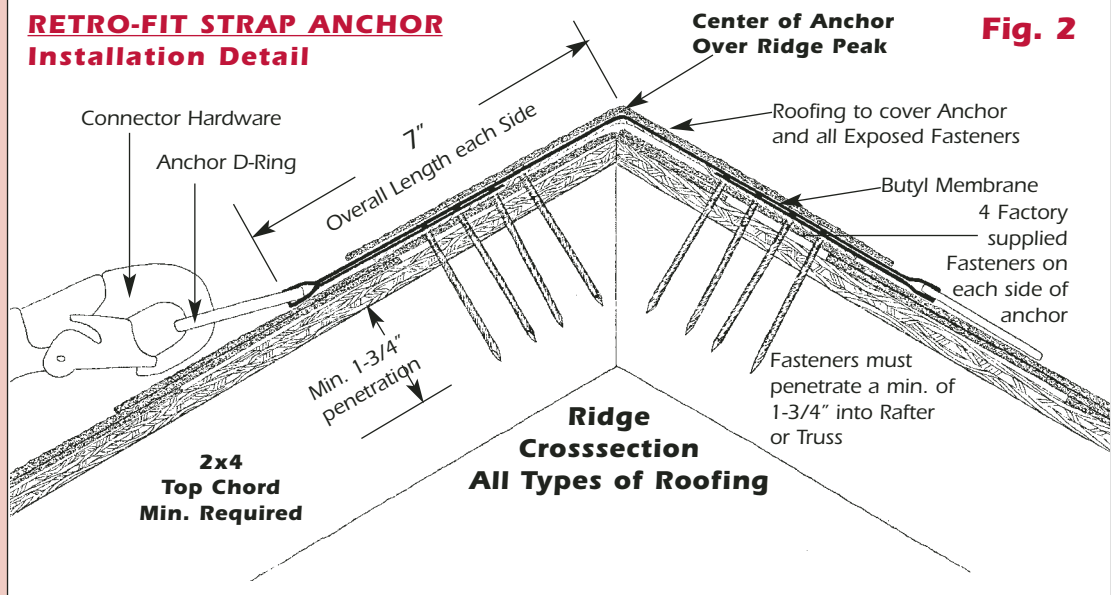
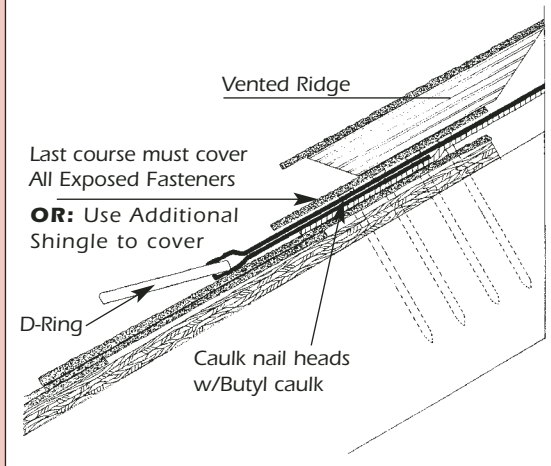

**Fig. 2**

### TOP CHORD CENTER:

In order to find the rafter or truss center, removal of the ridge and all layers of roofing membranes will be required. The exact center of the top chord should be verified. This can be accomplished by drilling inspection holes or cutting away portions of the sheathing at the ridge.

**Fig. 3 VENTED RIDGE DETAIL**



### FASTENERS:

Each anchor is required to have 8 factory supplied fasteners used to secure the anchor to the top chord or rafter through the roofing membranes and roof sheathing. See **Fig. 3.**

Fasteners are 10 Ga. spiral shank stainless steel. DO NOT substitute with any other fastener except those approved by **SUPER ANCHOR SAFETY**. Additional fastener packages may be requested by using **Part #2013A**, a replacement fastener package. Also approved for attachment is **Part #2009** - 10 Ea. 2-7/8" length red hex head screws.

Align anchor center over top chord center by using the "center nail holes" designated in **Fig. 1a**. Make sure fasteners are driven to the full depth with nail heads flush over the anchor face, and that no fasteners protrude the top chord sides. If a fastener is bent over, extract it and install a new one. The anchor is 14" in

length. Position the center 7" over the ridge center as shown in **Fig. 2.**

### CONNECTING HARDWARE:

Use only double locking snaphooks, thread locking or auto-locking carabiners to attach a lifeline or lanyard to one of the D-Rings located at either end of the anchor. Attach only to D-ring that is located on the side of the roof you are working on. Two persons are not allowed to connect to one anchor point at the same time.

### WARNING LABEL:

Make sure the warning label is attached to the anchor as shown in **Fig. 1a**, and exposed to the weather. DO NOT REMOVE.

### WATERPROOFING:

The anchor has a 2" wide strip of butyl membrane attached to the underside. This membrane will contact the top side of the roofing membrane and will provide a seal around the nail shanks. The nail heads should be caulked with butyl caulk only and the final layer of roofing membrane or ridge cap should cover all nail heads.

### IF A FALL OCCURS:

In the event a fall occurs, or the anchor is subjected to an impact load of any type, it must be removed from service and replaced.

**Fig. 4 WOOD SHAKE/SHINGLE RIDGE**

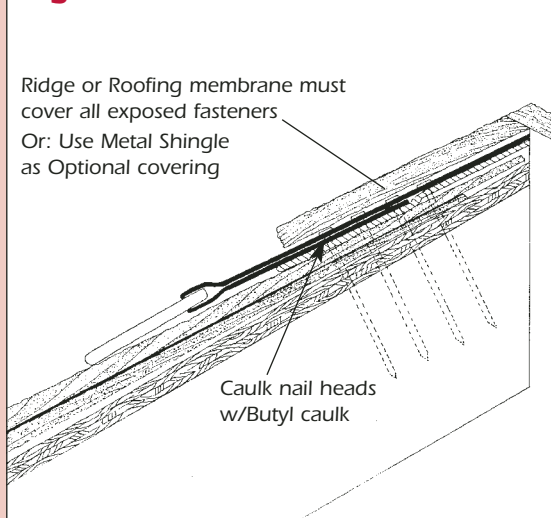

### VISIBLE INSPECTION BEFORE USE:

Before connecting to the anchor, inspect for any visible defect that might render the anchor unsafe for use. If the D-ring is bent, oblong, (does not conform to the dimensions shown in **Fig. 1**), or the anchor strap is twisted or bent, DO NOT USE the anchor. It must be replaced.

### \* FOOTNOTE:

**Fall impact loads are designed based on user weight, the length of a free fall, and the shock absorbing capability of the personal fall protection equipment used.**

Request additional information, service, or parts by contacting a factory authorized dealer or the manufacturer. See phone, and fax listed below. Our website lists dealers and additional equipment available. Request Spanish translation.

**WARNING:** THE RETROFIT ANCHOR IS DESIGNED TO BE USED OVER FRAMING STRUCTURES THAT HAVE SHEATHING IN PLACE AND WHERE THERE IS NO DANGER OF FALLING THROUGH THE FRAMING TO A LOWER LEVEL. WHEN THIS TYPE OF WORK IS BEING DONE, IT IS RECOMMENDED THAT YOU USE THE ARS 2X8 ANCHOR WHICH BOLTS UNDER THE RAFTER.

# SUPER ANCHOR SAFETY

8522 216 th. Street SE Woodinville, WA 98072-8009

Phone: (425) 488-8868 Fax: (360) 668-1717

## USER TRAINING FORM

The firm named below, provided training and instruction regarding the use, installation, and maintenance of;

- SUPER ANCHOR**® Fall Arrest Anchors
- SUPER ANCHOR**® Fall Restraint Safety Nail
- FALL ARRESTOR**® Lifeline / Rope Grab System
- Other; ( designate )

Firm Name: \_\_\_\_\_ Training by: \_\_\_\_\_  
 Address: \_\_\_\_\_ Title: \_\_\_\_\_  
 City: \_\_\_\_\_ Location: \_\_\_\_\_  
 Phone: \_\_\_\_\_ Date of training: \_\_\_\_\_

The above named company designates the following person as safety officer:

Name: \_\_\_\_\_ Title: \_\_\_\_\_

- Topics discussed;
- 1) Product installation and use.
  - 2) Fall Arrest safety standards and safety equipment use.
  - 3) Inspection of equipment, disposal of defective equipment; replacement
  - 4) Improper use of equipment and failure to use equipment
  - 5) When a fall occurs
  - 6) Company accident plan or fall prevention plan

Other topics; \_\_\_\_\_  
 \_\_\_\_\_

The following attendees have received instruction for use, installation and maintenance of the above designated safety equipment, and the topics noted above as well as any other additional topics noted. The manufacturer's authorized Instruction/Specification manual for the above designated safety equipment (boxes checked above) were used as a basis for instruction and training and each attendee was issued a copy of those manuals for his/her use.

**Note: Attach copies of all instructional materials used for a training record.**

### Attendee Roster:

Print your name here

Sign in here

Print your name here	Sign in here
1)	
2)	
3)	
4)	
5)	
6)	
7)	
8)	
9)	

**Continuation of Attendees:**

**Print your name here:**

**Sign in here:**

<b>10)</b>	
<b>11)</b>	
<b>12)</b>	
<b>13)</b>	
<b>14)</b>	
<b>15)</b>	
<b>16)</b>	
<b>17)</b>	
<b>18)</b>	
<b>19)</b>	
<b>20)</b>	
<b>21)</b>	
<b>22)</b>	
<b>23)</b>	
<b>24)</b>	
<b>25)</b>	
<b>26)</b>	
<b>27)</b>	
<b>28)</b>	
<b>29)</b>	
<b>30)</b>	
<b>31)</b>	
<b>32)</b>	
<b>33)</b>	
<b>34)</b>	
<b>35)</b>	
<b>36)</b>	
<b>37)</b>	
<b>38)</b>	
<b>39)</b>	
<b>40)</b>	
<b>41)</b>	
<b>42)</b>	
<b>43)</b>	
<b>44)</b>	
<b>45)</b>	
<b>46)</b>	
<b>47)</b>	
<b>48)</b>	
<b>49)</b>	
<b>50)</b>	
<b>51)</b>	
<b>52)</b>	



**SUPER ANCHOR SAFETY**

8522 216th Street SE • Woodinville, WA 98072-8009

Phone (425) 488-8868 or Fax us at (360) 668-1717

email: [paul@superanchor.com](mailto:paul@superanchor.com)

Visit Our Website at [www.superanchor.com](http://www.superanchor.com)